

**TOSVERT VF-AS1**

---

**My Function Instruction Manual**

---

January 2006

**(C) Toshiba Inverter Corporation 2006**  
**All rights reserved.**

---

**Contents**

---

<b>CONTENTS</b> .....	<b>1</b>
<b>1. INTRODUCTION</b> .....	<b>2</b>
<b>2. PARAMETERS USED</b> .....	<b>2</b>
<b>3. LOGIC INPUT/OUTPUT MY FUNCTION</b> .....	<b>2</b>
<b>4. SETTING PARAMETERS</b> .....	<b>5</b>
<b>5. EXAMPLES OF SETTING</b> .....	<b>12</b>
<b>6. ANALOG INPUT MY FUNCTION</b> .....	<b>25</b>
<b>7. ANALOG OUTPUT MY FUNCTION</b> .....	<b>29</b>
<b>APPENDIX 1 TABLE OF MY FUNCTION PARAMETERS</b> .....	<b>30</b>
<b>APPENDIX 2 COMPUTING FUNCTIONS</b> .....	<b>32</b>
<b>APPENDIX 3 INPUT TERMINAL FUNCTION SELECTION PARAMETERS</b> .....	<b>33</b>
<b>APPENDIX 4 OUTPUT TERMINAL FUNCTION SELECTION PARAMETERS</b> .....	<b>35</b>
<b>APPENDIX 5 INTERNAL DATA</b> .....	<b>39</b>
<b>APPENDIX 6 EXAMPLES OF COMPUTING FUNCTION SETTINGS</b> .....	<b>41</b>

## 1. Introduction

VFAS1's My function adds programming capability to inverter's input/output signals to respond to customer needs without external relays or a PLC (programmable logic controller) in some cases. Therefore, My function makes it possible to reduce the space and cost required for the system.

My function has three types in below:

1. Logic input/output My function simplifies relay sequence operations.
2. Analog input My function changes parameter settings by the analog input signals.
3. Analog output My function gets the analog output signals of the maximum and minimum values displayed by the monitor function.

⇒ For details of each function, refer to the relevant section.

## 2. Parameters used

My functions use the parameters *F900* to *F977*.

⇒ For details of each parameter, refer to the relevant section.

## 3. Logic input/output My function

This chapter explains the logic input/output My function, which is typified by the combined terminal function that combines the functions of the inverter's input and output terminals and the relay sequence function that combines logic operation functions.

### ■ Combined terminal function

The combined terminal function works to assign two or more functions to one terminal. Using this function, you can assign, for example, the operation ready signal input function (this function is set to the ST terminal by default ) and the forward run start signal input function ( this function is set to the S1 terminal by default ) to one terminal. This enables the S1 terminal to perform the same function that the two terminals, ST and F, perform when they are turned on and off (for an explanation of the actual program, see Example 1 in Chapter 5). This function, therefore, makes it possible to reduce the numbers of terminals and cables required for the desired operations.

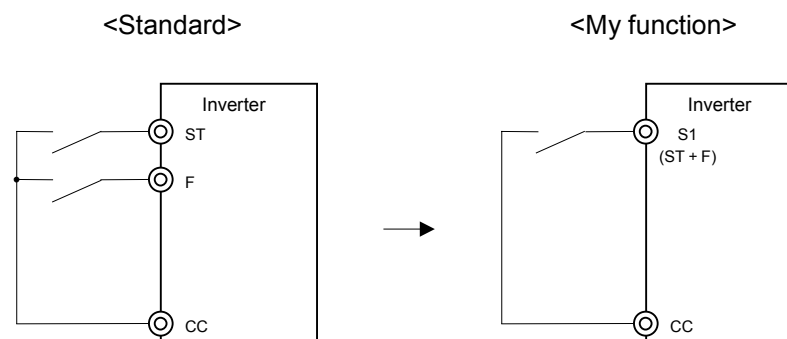

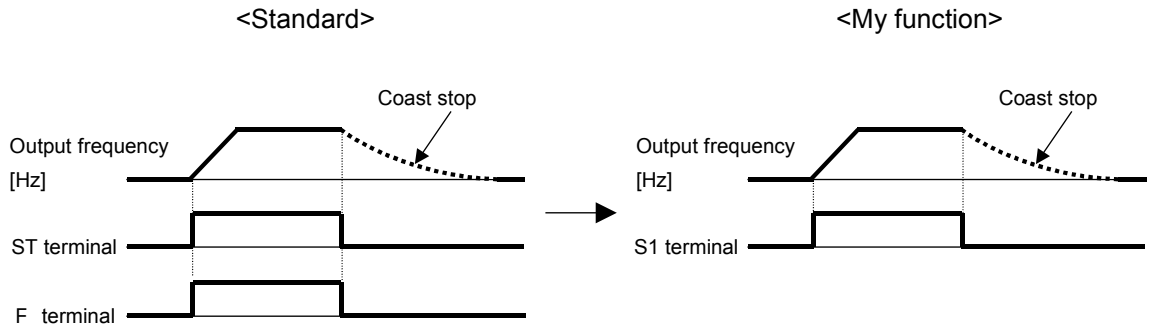

The combined terminal function can be used with both signal input terminals and signal output terminals.

For example, this function works to set the OUT1 output terminal so as to put out a signal in the condition that both a low-speed signal (output terminal function 4) and a low-current detection signal (output terminal function 26) are detected. (For an explanation of the actual program, see Example 3 in Chapter 5).

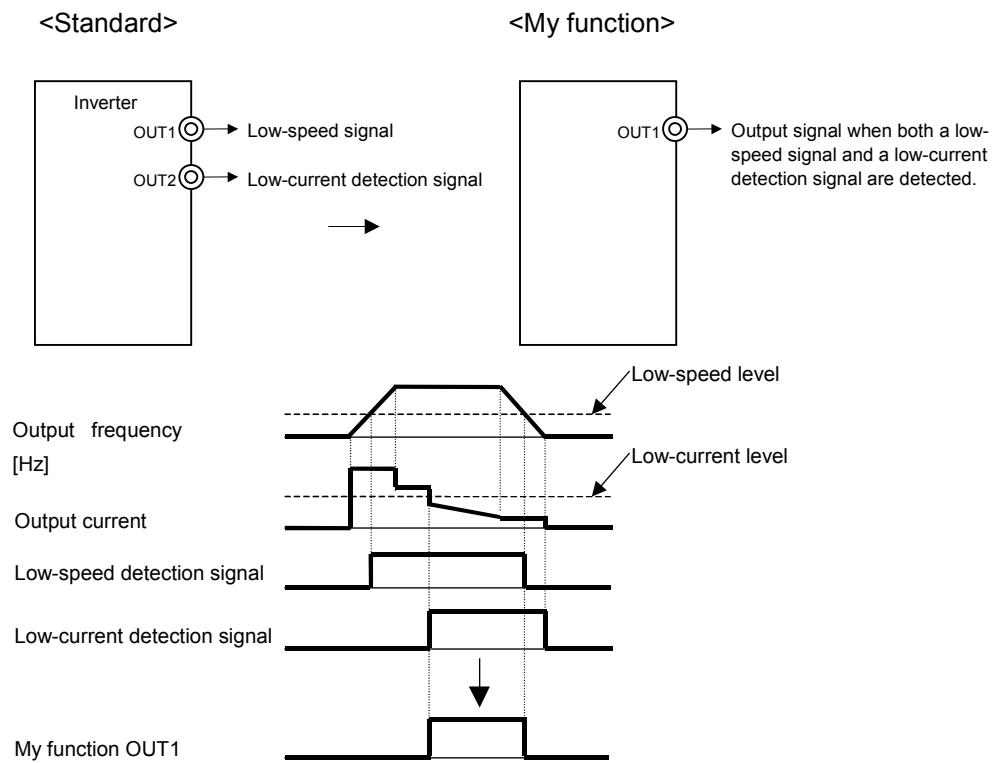

My function sets output signals to be combined together, and therefore enables the inverter to perform additional operations itself that have been carried out conventionally with a sequence for the operation of external relays.

■ Relay sequence function

Assume that an inverter and a PLC (programmable logic controller) are used to operate a system. In that case, the PLC receives several signals from external devices, processes the received signals according to the program in it, and sends the signals as processing result to the inverter. (See Figure 3-1.)

The relay sequence function enables the inverter to perform all steps of operation itself without the help of a PLC. This means that this function allows the inverter to directly process data and signals in it, and therefore increases its speed of response by eliminating the need to exchange data with the PLC.

Furthermore, this function enables the inverter to use its multi-function input and output signals at the same time, and thus to perform various operations in a reduced number of steps.

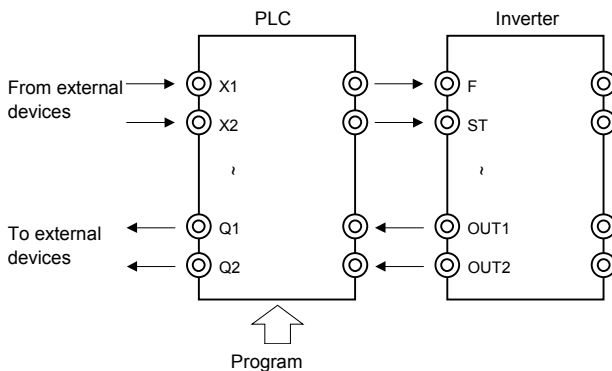

Fig. 3-1 Signal flow between PCL and inverter

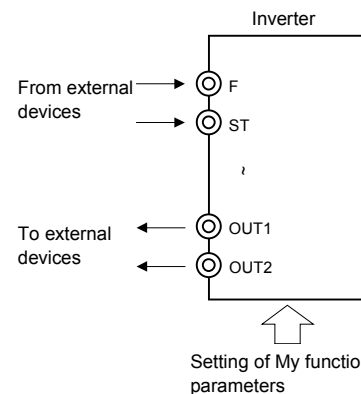

Fig. 3-2 Signal flow of inverter with My function

An example is shown the relay sequence function in below. For the steps to be followed when creating a program, a concrete explanation is given in the next and subsequent chapters.

«Example» To set the inverter so that it will start operation when receiving a forward run signal in push mode (in which signals received are held effective) and stop operation automatically if the output current increases to 120% or more of the specified current when the operation frequency is 5Hz or below.

For the sake of simplicity, stop signal input terminals are omitted here.  
(For an explanation of the actual program, see Example 6 in Chapter 5.)

● Input and output symbols

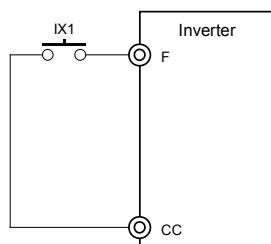

● Timing chart



## 4. Setting parameters

This chapter explains how to set parameters related to the logic input/output My function using examples of setting, the composition of My functions, and the rules for them.

### ■ Types and applications of input terminals

Here is the composition of the input signal terminals that can be used with the logic input/output My function.

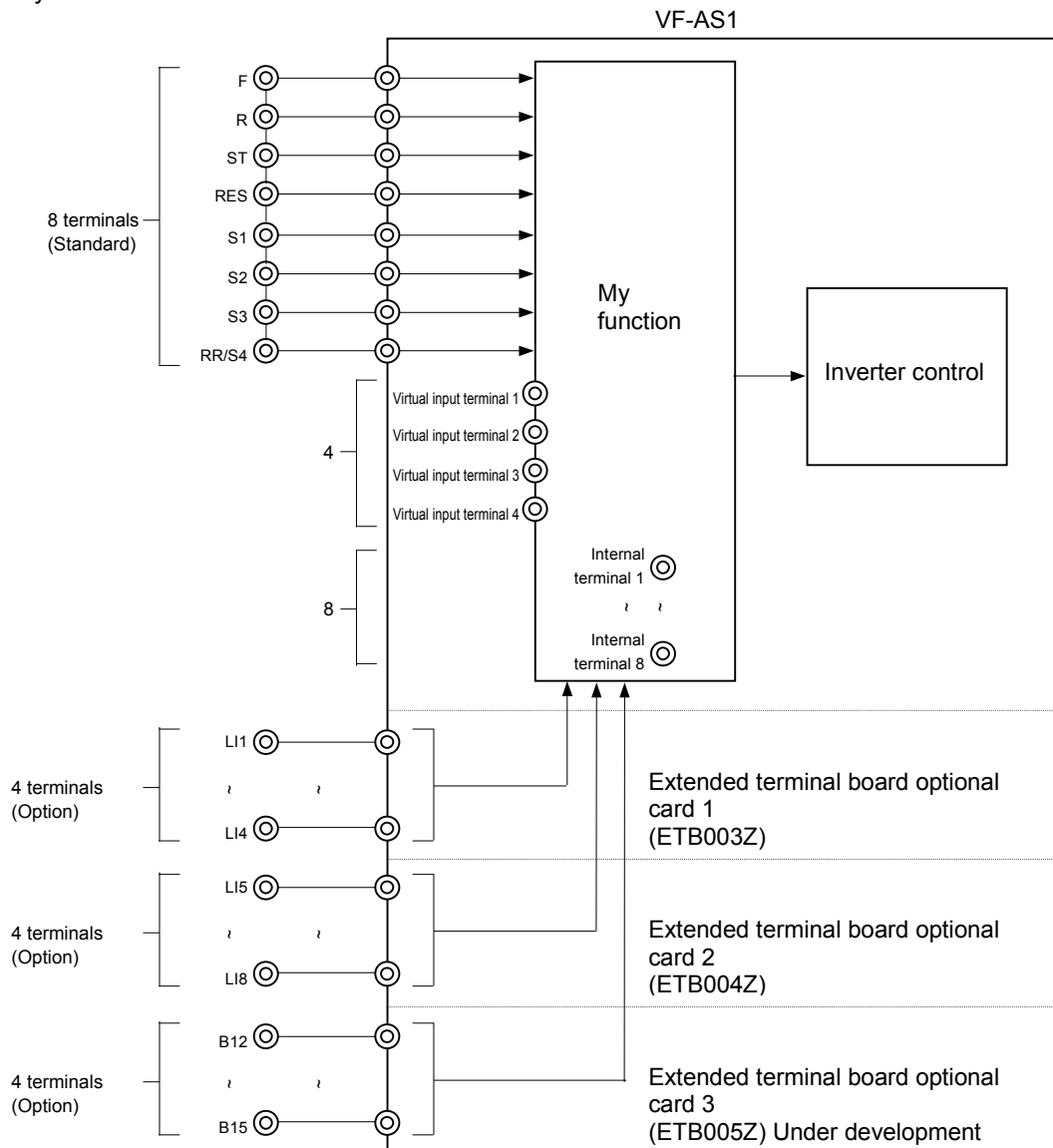

● **Input terminals (20 terminals: F, R, ST, RES, S1 to S3, RR/S4, L11 to L18 and B12 to B15)**

There are two methods of assigning My functions to input terminals: assigning only ON-OFF signal input functions to input terminals, as with a PLC, but not multiple functions (such input terminals are referred to as X1, X2 to X20 to distinguish them from those to which multiple functions are assigned, although they are the same terminals), and assigning multiple functions to input terminals (assigning functions listed in Table 8-4 of Appendix 3 to input terminals) to use them along with My functions.

The combined terminal function described in the previous chapter uses mainly the former method, whereas the relay sequence function uses both the former and latter methods in some cases.

• **Virtual input terminals (4 terminals)**

VFAS1 has 4 virtual input terminals for My function.

Although these terminals do not actually exist, input terminal functions (0 to 135. See Table 8-4 in Appendix 3) can be assigned to them, just as with actual input terminals. A virtual terminal can be used, for example, as the ST+F terminal, if a value read from the actual terminal is written on it.

• **Internal terminals (8 terminals)**

VFAS1 has 8 internal terminals for My function.

Actually, these terminals do not exist either but they can be used to link signals. These internal terminals aren't same as the virtual input terminals. They are used, for example, to link signals logically to allow the inverter to proceed with the next process.

■ **Computing function**

My function performs logical operations on input/output signals and compares and computes some data, such as frequency, current and torque data, that the inverter detects. The figures below show the outline.

A table of computing functions is shown in Appendix 2. Data items that inverter detects available are listed in Appendix 5. The computing function enhances the speed of analog data processing, which is a problem with data processing by a PLC.

• **Logical comparison**

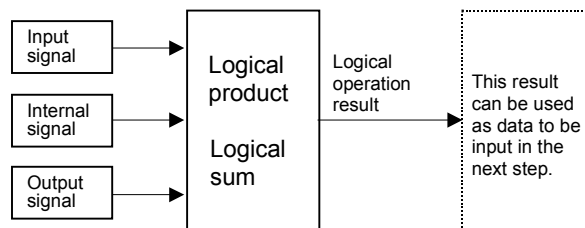

• **Commutation**

Comparison and computation of data

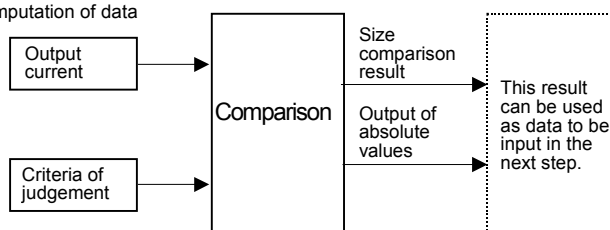

■ **Functions and applications of output terminals**

Functions to be assigned to the output terminals OUT1 to OUT6, FL and R1 to R4 have to be selected from among the positive-logic options for the output terminal functions (0 to 255) listed in Appendix 4. Note that negative-logic settings cannot be used for the output terminals.

My function adds My function output terminal functions to the output multiple-functions (222 to 253), as shown in Appendix 4. These functions let the inverter put out computation results mentioned in the above section through its output terminals and allows My function to use the computation results for itself.

Here is a block diagram of My function with output terminals used with it.

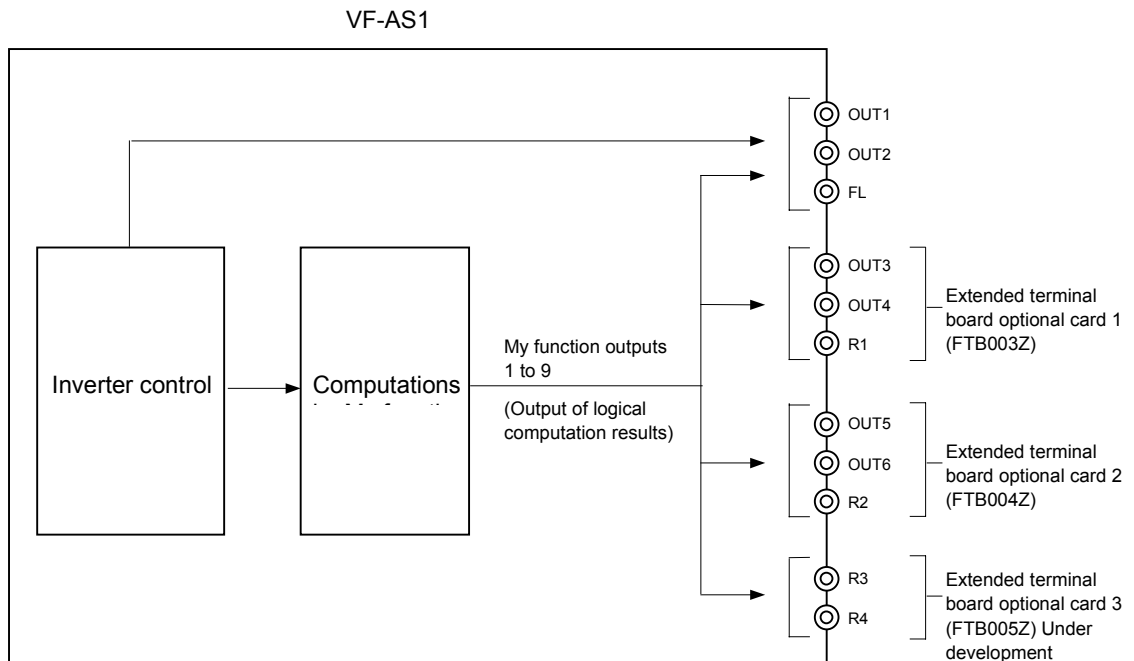

■ Setting parameters

This section explains concretely how to set My function parameters to use the desired function. The logic input/output My function consists of 7 units of the same composition. Each unit consists of 4 steps, and therefore there are 28 steps in total. See 4-1 for the composition of each unit. Each step consists of one command, and each unit begins with a data read (LD) command (step 1) and ends with a data transfer (ST) command (step 4). These two commands are already incorporated into each unit. The command for performing the desired function and the object to which the command is issued are specified for the two steps (steps 2 and 3) in between them. This is a rule for using My function.

Unit 1			Unit 2			Unit 7	
Step 1	LD F900		Step 1	LD F906		Step 1	LD F953
Step 2	F901 F902	→	Step 2	F907 F908	→→	Step 2	F954 F955
Step 3	F903 F904		Step 3	F909 F910		Step 3	F956 F957
Step 4	ST F905		Step 4	ST F911		Step 4	ST F958

Fig. 4-1 My function block diagram



## ■ Parameters used

The table below lists the parameters shown in My function block diagram.

Table 4-1 Table of My function parameters

		Title	Function	Adjustment range	Default setting
Unit 1	Step 1 (Objects)	<i>F 900</i>	Input function target 11	Input terminal number 0: Deselect 1: F terminal 2: R terminal 3: ST terminal 4: RES terminal 5: S1 terminal 6: S2 terminal 7: S3 terminal 8: RR/S4 terminal 9: LI1 terminal 10: LI2 terminal 11: LI3 terminal 12: LI4 terminal 13: LI5 terminal 14: LI6 terminal 15: LI7 terminal 16: LI8 terminal 17: B12 terminal 18: B13 terminal 19: B14 terminal 20: B15 terminal 21: Virtual input terminal 1 22: Virtual input terminal 2 23: Virtual input terminal 3 24: Virtual input terminal 4 25~32: Internal terminal 1~8 918~934: My output data No. 1000~1255: Output selection number (Note 1) 2000~2099: FD00~FD99 (Note 2) 3000~3099: FE00~FE99 (Note 2)	0
	Step 2 (Commands)	<i>F 901</i>	Input function target 12	0: NOP (disabling) 1: ST (move) 2: STN (move (inversion)) 3: AND (logical product (A B)) 4: ANDN (logical product (A B)) 5: OR (logical sum (A B)) 6: ORN (logical sum (A B)) 7: EQ (equal) 8: NE (not equal) 9: GT (greater than) 10: GE (greater or equal) 11: LT (less than) 12: LE (less or equal) 13: ASUB (absolute) 14: ON (on delay timer) 15: OFF (off delay timer) 16: COUNT1 (counter 1) 17: COUNT2 (counter 2) 18: HOLD (hold) 19: SET (set) 20: RESET (reset)	0
	Step 2 (Objects)	<i>F 902</i>	Input function target 12	Same as <i>F 900</i>	0
	Step 3 (Commands)	<i>F 903</i>	Input function command 13	Same as <i>F 901</i>	0
	Step 3 (Objects)	<i>F 904</i>	Input function target 13	Same as <i>F 900</i>	0
	Step 4 (Output to)	<i>F 905</i>	Output function assigned object 1	Same as <i>F 900</i>	0

		Title	Function	Adjustment range	Default setting
Unit 2	Step 1 (Objects)	F906	Input function target 21	Same as F900	0
	Step 2 (Commands)	F907	Input function target 22	Same as F901	0
	Step 2 (Objects)	F908	Input function target 22	Same as F900	0
	Step 3 (Commands)	F909	Input function target 23	Same as F901	0
	Step 3 (Objects)	F910	Input function target 23	Same as F900	0
	Step 4 (Output to)	F911	Output function assigned object 2	Same as F900	0
Unit 3	Step 1 (Objects)	F912	Input function target 31	Same as F900	0
	Step 2 (Commands)	F913	Input function target	Same as F901	0
	Step 2 (Objects)	F914	Input function target 32	Same as F900	0
	Step 3 (Commands)	F915	Input function target	Same as F901	0
	Step 3 (Objects)	F916	Input function target 33	Same as F900	0
	Step 4 (Output to)	F917	Output function assigned object 3	Same as F900	0
Unit 4	Step 1 (Objects)	F935	Input function target 41	Same as F900	0
	Step 2 (Commands)	F936	Input function target 42	Same as F901	0
	Step 2 (Objects)	F937	Input function target 42	Same as F900	0
	Step 3 (Commands)	F938	Input function target 43	Same as F901	0
	Step 3 (Objects)	F939	Input function target 43	Same as F900	0
	Step 4 (Output to)	F940	Output function assigned object 4	Same as F900	0
Unit 5	Step 1 (Objects)	F941	Input function target 51	Same as F900	0
	Step 2 (Commands)	F942	Input function target 52	Same as F901	0
	Step 2 (Objects)	F943	Input function target 52	Same as F900	0
	Step 3 (Commands)	F944	Input function target 53	Same as F901	0
	Step 3 (Objects)	F945	Input function target 53	Same as F900	0
	Step 4 (Output to)	F946	Output function assigned object 5	Same as F900	0
Unit 6	Step 1 (Objects)	F947	Input function target 61	Same as F900	0
	Step 2 (Commands)	F948	Input function target 62	Same as F901	0
	Step 2 (Objects)	F949	Input function target 62	Same as F900	0
	Step 3 (Commands)	F950	Input function target 63	Same as F901	0
	Step 3 (Objects)	F951	Input function target 63	Same as F900	0
	Step 4 (Output to)	F952	Output function assigned object 6	Same as F900	0

		Title	Function	Adjustment range	Default setting
Unit 7	Step 1 (Objects)	<i>F 953</i>	Input function target 71	Same as <i>F 900</i>	<i>0</i>
	Step 2 (Commands)	<i>F 954</i>	Input function target 72	Same as <i>F 901</i>	<i>0</i>
	Step 2 (Objects)	<i>F 955</i>	Input function target 72	Same as <i>F 900</i>	<i>0</i>
	Step 3 (Commands)	<i>F 956</i>	Input function target 73	Same as <i>F 901</i>	<i>0</i>
	Step 3 (Objects)	<i>F 957</i>	Input function target 73	Same as <i>F 900</i>	<i>0</i>
	Step 4 (Output to)	<i>F 958</i>	Output function assigned object 7	Same as <i>F 900</i>	<i>0</i>

Note 1: See Table 8-6 “Output terminal functions” in Appendix 4.

Note 2: See Table 8-7 “Data that My function can handle” in Appendix 5.

The four kinds of data in the table below: percent, frequency, time (second) and count, can be compared and computed, and they are specified with parameters for the object to which commands are issued.

Title	Function	Adjustment range	Default setting
<i>F 918</i>	My output percent data 1	<i>0.00~200.0%</i>	<i>0.00</i>
<i>F 919</i>	My output percent data 2	<i>0.00~200.0%</i>	<i>0.00</i>
<i>F 920</i>	My output percent data 3	<i>0.00~200.0%</i>	<i>0.00</i>
<i>F 921</i>	My output percent data 4	<i>0.00~200.0%</i>	<i>0.00</i>
<i>F 922</i>	My output percent data 5	<i>0.00~200.0%</i>	<i>0.00</i>
<i>F 923</i>	My output frequency data 1	<i>0.0~500.0Hz</i>	<i>0.0</i>
<i>F 924</i>	My output frequency data 2	<i>0.0~500.0Hz</i>	<i>0.0</i>
<i>F 925</i>	My output frequency data 3	<i>0.0~500.0Hz</i>	<i>0.0</i>
<i>F 926</i>	My output frequency data 4	<i>0.0~500.0Hz</i>	<i>0.0</i>
<i>F 927</i>	My output frequency data 5	<i>0.0~500.0Hz</i>	<i>0.0</i>
<i>F 928</i>	My output time data 1	<i>0.0 1~600.0s</i>	<i>0.0 1</i>
<i>F 929</i>	My output time data 2	<i>0.0 1~600.0s</i>	<i>0.0 1</i>
<i>F 930</i>	My output time data 3	<i>0.0 1~600.0s</i>	<i>0.0 1</i>
<i>F 931</i>	My output time data 4	<i>0.0 1~600.0s</i>	<i>0.0 1</i>
<i>F 932</i>	My output time data 5	<i>0.0 1~600.0s</i>	<i>0.0 1</i>
<i>F 933</i>	No. of times of My output data 1	<i>0~9999 times</i>	<i>0</i>
<i>F 934</i>	No. of times of My output data 2	<i>0~9999 times</i>	<i>0</i>

The table below lists the four virtual input terminals available.

Title	Function	Adjustment range (Note 1)	Default setting
<i>F 973</i>	Virtual input terminal selection 1	<i>0~135</i>	<i>0</i>
<i>F 974</i>	Virtual input terminal selection 2	<i>0~135</i>	<i>0</i>
<i>F 975</i>	Virtual input terminal selection 3	<i>0~135</i>	<i>0</i>
<i>F 976</i>	Virtual input terminal selection 4	<i>0~135</i>	<i>0</i>

Note 1: See Table 8-4 “Input terminal functions” in Appendix 3.

## ■ Enabling or disabling MY function

A parameter for enabling or disabling My function is provided to prevent the system from starting accidentally during the setting of My function parameters. This parameter is  $F977$  described below. When setting My function parameters, be sure to set  $F977$  to  $0$  (unselected) to disable My function.

After setting necessary My function parameters, change the setting to  $1$  (My function + enabling signal) or  $2$  (My function always enabled) to make My function ready to work. (If  $F977$  is set to  $1$ , MY function is activated when an enabling signal is issued.)

Note: It takes a maximum of 0.5 second for a change to a logic input/output My function-related parameter to take effect. Therefore, the inverter must be held in a standby state for at least 0.5 second after the setting of necessary My function parameters.

Title	Function	Adjustment range	Default setting
$F977$	My function selection	$0$ : Deselect $1$ : My function + permission signal $2$ : My function always ON	$0$

$0$  (Unselected): Disables My function.

$1$  (My function + enabling signal): Puts My function into a standby state. My function starts working when an ON signal is sent to the terminals to which the input terminal functions  $54$  and  $55$  (My function RUN signal) are assigned.

$2$  (My function always enabled): Enables My function as soon as the inverter is turned on.

Note: The setting of the parameter  $F977$  cannot be changed when the inverter is in operation.

### ● When MY function is disabled

All My function settings are ineffective. Instead, original input terminal settings are effective and the inverter operates in the usual way.

### ● When MY function is in a standby state

All signals (except some signals) coming in through input terminals are turned OFF in the inverter and recognized as OFF signals. This does not hold true for the following functions.

1. My function enabling function
2. Emergency stop function and reset function

Note: Using My function, do not operate the input terminals to which the above functions are assigned. Or My function enabling function, the emergency stop function, etc might not work normally.

### ● When MY function is enabled

Signals coming in through input terminals are rewritten in the inverter according to the settings of My function and the inverter operates under the rewritten signals.

## 5. Examples of setting

This chapter gives several examples of setting.

Note that the settings described below are examples and there are several ways to set a function. Here are the examples of setting given in this chapter.

- **Examples of the setting of the combined terminal function**

Example 1: Performing the ST+F function by sending a signal to one terminal

Example 2: Performing the ST+F+Sr function by sending a signal to one terminal

Example 3: Putting out the logical product of a low-speed signal and a low-current signal

- **Examples of the setting of the relay sequence function**

Example 4: Operation with a combination of 2 input signals

Example 5: Push type operation

Example 6: Operation with the automatic stop function

### ■ Examples of the setting of the combined terminal function

«Example 1: Performing the ST+F function by sending a signal to one terminal»

Here is an example of the assignment of the ST+F combined function referred to in Chapter 3 to the S1 terminal, including the setting of related parameters. Figure 5-1 illustrates this example. To perform this function, the inverter needs to be configured, as shown in Figure 5-2. The ST function is assigned to the S1 terminal as an ordinary input terminal function, and the F function is assigned to a virtual input terminal of MY function. If a signal to the S1 terminal is transferred to the virtual input terminal under these conditions, the S1 terminal turns on and performs the ST+F function.

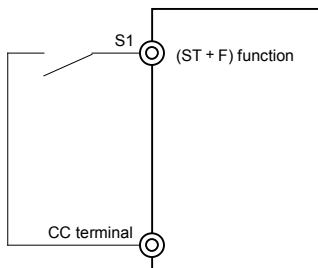

Fig. 5-1 Wiring diagram for Example 1

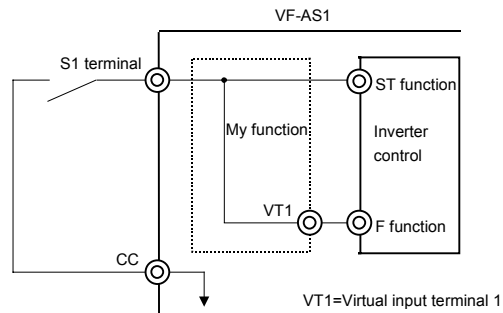

Fig. 5-2 Block diagram for Example 1

Follow these steps to set parameters.

1. First, disable My function to prevent the system from starting accidentally during the setting of My function parameters. (Factory default setting)

$F 9 7 7 = 0$  (Disables MY function)

2. Assign the ST function to the S1 terminal to which the preset speed command 1 function (S1) is currently assigned by factory default.

$F 1 1 5 = 6$  (S1 terminal = Ready for ST operation)

3. Using  $F 9 7 3$ , assign forward run command F to virtual input terminal 1.

$F 9 7 3 = 2$  (Virtual input terminal 1 = Forward run command F)

4. Then specify commands in accordance with MY function block diagram, and objects to which the commands are issued.

«Unit 1»	Commands	Objects	
Step 1	LD	<i>F900=5</i>	Command for reading S1 terminal input signals
Step 2	<i>F901=0</i>	<i>F902=0</i>	Disabling command, because there is no need to specify this in this example.
Step 3	<i>F903=0</i>	<i>F904=0</i>	Disabling command, because there is no need to specify this in this example.
Step 4	ST	<i>F905=2 1</i>	Command for writing signals read in step 1 to virtual input terminal 1

5. After setting the above My function parameters, set My function ON/OFF selection parameter to 2 (always enabled) to enable My function.

*F977=2* (My function always enabled)

These settings are summarized in the table below.

		Title	Parameter setting	Description
Prior setting	-	<i>F977</i>	0 (Default)	Disables My function.
		<i>F115</i>	6	Assigns the ST terminal function to the S1 terminal.
		<i>F973</i>	2	Assigns the F terminal function to virtual input terminal 1.
Unit 1	Step 1	<i>F900</i>	5	Reads S1 terminal input signals (LD S1).
	Step 2	<i>F901</i>	0 (Default)	NOP command (Disabling)
		<i>F902</i>	0 (Default)	
	Step 3	<i>F903</i>	0 (Default)	NOP command (Disabling)
		<i>F904</i>	0 (Default)	
Step 4	<i>F905</i>	2 1	Incorporates the result into virtual input terminal 1.	
-	-	<i>F977</i>	2	Sets My function ON/OFF selection parameter to Always enabled.

«Example 2: Performing the ST+F+Sr function by sending a signal to one terminal»

This section explains how to set parameters to perform three input terminal functions (ST+F+Sr1) by sending a signal to one terminal (S1 terminal).

Figure 5-3 illustrates this example. To perform this function, the inverter needs to be configured, as shown in Figure 5-4. The ST function, a multi-function input terminal function, is assigned to the S1 terminal, just as with Example 1. In addition, the F function and the preset speed command 1 function are assigned to virtual input terminals 1 and 2 of MY function, respectively. If a signal to the S1 terminal is transferred to the virtual terminals under these conditions, the S1 terminal turns on and performs the ST+F+Sr1 function.

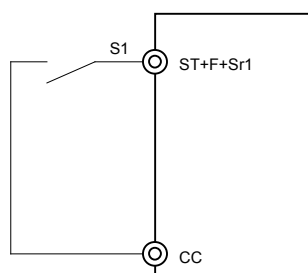

Fig. 5-3 Wiring diagram for Example 2

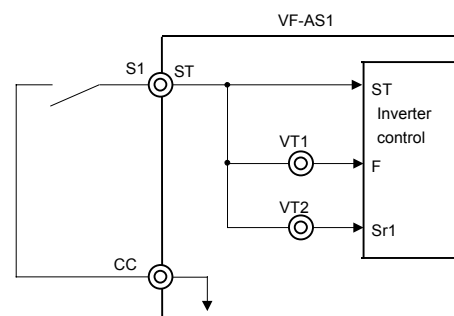

Fig. 5-4 Block diagram for Example 2

Follow these steps to set parameters.

1. As with the above example, disable My function first to prevent the system from starting accidentally during the setting of My function parameters.  
*F 9 7 7=0* (Disables MY function)
  2. Assign the ST function to the S1 terminal to which the preset speed command 1 function (S1) is currently assigned by factory default.  
*F 1 1 5=6* (S1 terminal = Ready for ST operation)
  3. Using *F 9 7 3*, assign forward run command F to virtual input terminal 1.  
*F 9 7 3=2* (VT1 (Virtual input terminal 1) = Forward run command F)
  4. Using *F 9 7 4*, assign preset speed command 1 to virtual input terminal 2.  
*F 9 7 4= 10* (VT2 (Virtual input terminal 2) = Preset speed command 1)
5. Then specify commands in accordance with My function block diagram, and objects to which the commands are issued.

«Unit 1»	Commands	Objects	
Step 1	LD	<i>F 9 0 0=5</i>	Command for reading S1 terminal input signals
Step 2	<i>F 9 0 1= 1</i>	<i>F 9 0 2=2 1</i>	Command for writing signals read in step 1 to virtual input terminal 1
Step 3	<i>F 9 0 3=0</i>	<i>F 9 0 4=0</i>	NOP command
Step 4	ST	<i>F 9 0 5=2 2</i>	Command for writing signals read in step 1 to virtual input terminal 2

6. After setting the above My function parameters, set My function ON/OFF selection parameter to 2 (always enabled) to enable MY function.  
*F 9 7 7=2* (My function always enabled)

These settings are summarized in the table below.

		Title	Parameter setting	Description
Prior setting	-	<i>F 9 7 7</i>	0 (Default)	Disables My function.
		<i>F 1 1 5</i>	6	Assigns the ST terminal function to the S1 terminal.
		<i>F 9 7 3</i>	2	Assigns the F terminal function to virtual input terminal 1.
		<i>F 9 7 4</i>	10	Assigns the preset speed command 1 to virtual input terminal 2.
Unit 1	Step 1	<i>F 9 0 0</i>	5	Reads S1 terminal input signals (LD S1).
	Step 2	<i>F 9 0 1</i>	1	Transfer command
		<i>F 9 0 2</i>	2 1	Incorporates the result into virtual input terminal 1.
	Step 3	<i>F 9 0 3</i>	0 (Default)	NOP command (Disabling)
		<i>F 9 0 4</i>	0 (Default)	
Step 4	<i>F 9 0 5</i>	2 2	Incorporates the result into virtual input terminal 2.	
-	-	<i>F 9 7 7</i>	2	Sets My function ON/OFF selection parameter to Always enabled.

«Example 3: Putting out the logical product of a low-speed signal and a low-current signal»

Here is an example of the combining of output signals referred to in Chapter 3. Only when both a low-speed signal and a low-current detection signal are received, a signal is sent out through an output terminal (OUT1).

Logical operations are performed, as shown in Fig. 5-5, to determine the logical product (AND) of a low-speed signal and a low-current detection signal included among multi-function output signals. To put out the computing result to the OUT1 output terminal, the logical product (AND) is temporarily written to My function output 1, and then My function output 1 sends the logical product to OUT1.

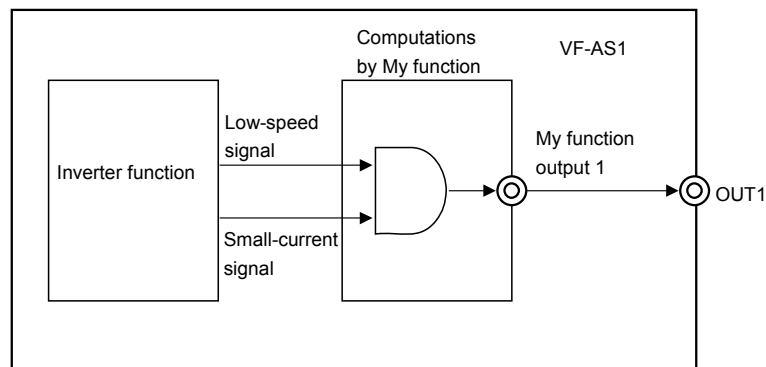

Fig. 5-5 Block diagram for Example 3

Follow these steps to set parameters.

1. As with the above example, disable My function first to prevent the system from starting accidentally during the setting of My function parameters.  
 $F977=0$  (Disables MY function)
2. Assign My function output 1 to the OUT1 output terminal to which the low-speed signal function is currently assigned by factory default.  
 $F130=222$  (Assigns My function output 1 to the OUT1 output terminal.)

3. Then set parameters in accordance with MY function block diagram.

«Unit 1»	Commands	Objects	
Step 1	LD	$F900=1004$	Reads low-speed signals.
Step 2	$F901=3$	$F902=1026$	Determines the logical product of a low-speed signal and low-current signal.
Step 3	$F903=0$	$F904=0$	NOP command
Step 4	ST	$F905=1222$	Incorporates the logical product into My function output 1.

4. After setting the above My function parameters, set My function ON/OFF selection parameter to 2 (always enabled) to enable My function.  
 $F977=2$  (My function always enabled)



These settings are summarized in the table below.

		Title	Parameter setting	Description
Prior setting	-	F977	0 (Default)	Disables My function.
		F130	222	Assigns My function output 1 to the OUT1 terminal.
Unit 1	Step 1	F900	1004	Reads low-speed signals (LD LOW)
	Step 2	F901	3	AND command
		F902	1026	Determines the logical product of a low-speed signal and low-current signal.
	Step 3	F903	0 (Default)	NOP command (Disabling)
		F904	0 (Default)	
Step 4	F905	1222	Incorporates the logical product into My function output 1. (ST My function output 1)	
-	-	F977	2	Sets My function ON/OFF selection parameter to Always enabled.

### ■ Examples of the setting of the relay sequence function

Since the steps to be followed to set the relay terminal function are much larger in number than those for the combined terminal function described earlier in this chapter, an explanation is given in the following order, using ladder diagrams.

Desired function ⇒ Input/output terminal wiring diagram ⇒ Timing chart ⇒ Ladder diagram  
⇒ Setting of parameters

First cited is an example of using input terminals as simple ON/OFF signal input terminals but not as multi-function signal input terminals.

«Example 4: Operation with a combination of 2 input signals»

The inverter is programmed with My function so that it will issue a forward run command if either input terminal 1 (F terminal in this example) or input terminal 2 (R terminal in this example) is turned on, or a reverse run command if both the input terminals are turned on, or a stop command if both the terminals are turned off.

Figure 5-6 illustrates a wiring diagram and a timing chart for this example.

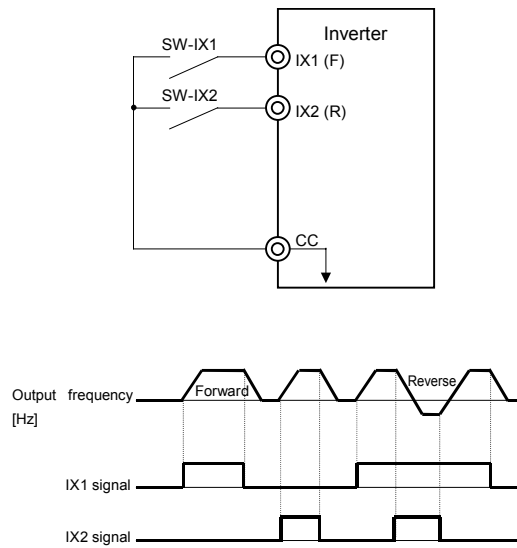
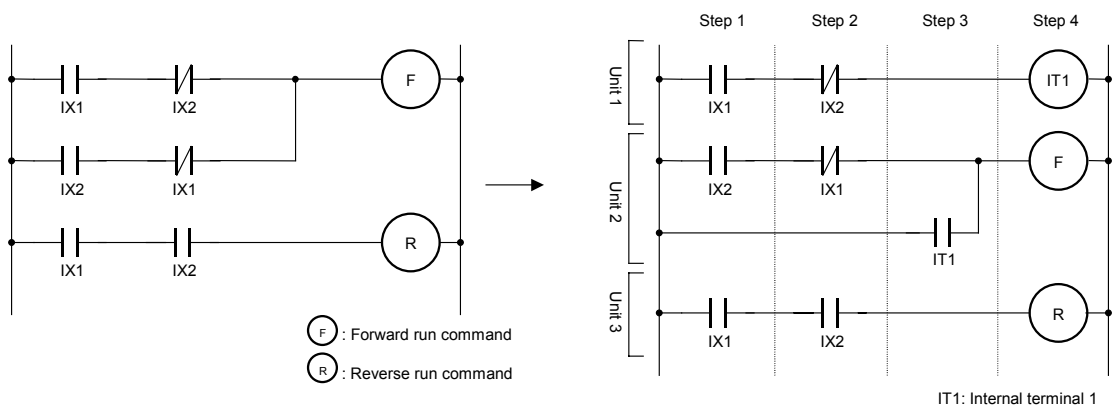

Fig. 5-6 Wiring diagram and timing chart for Example 4

To facilitate the setting of parameters, these relationships are illustrated in the ladder diagram below.



Unit 1 of My function consists of up to 4 steps. The sequence for issuing a reverse run command shown in the ladder diagram on the left consists of 5 steps. If these steps are divided between two units and recomposed, as shown in the diagram on the right, the same function can be performed with My function.

The above ladder diagram suggests that My function parameters listed in the table below need to be set.

		Title	Parameter setting	Description
Prior setting	-	<i>F977</i>	0 (Default)	Disables My function to prevent the system from starting accidentally during the setting of parameters.
		<i>F111</i>	0	Uses the F terminal as a simple input terminal (IX1) but not as a multi-function terminal.
		<i>F112</i>	0	Uses the R terminal as a simple input terminal (IX2) but not as a multi-function terminal.
		<i>F973</i>	2	Assigns the forward run command function to virtual input terminal 1 (VT1).
		<i>F974</i>	4	Assigns the reverse run command function to virtual input terminal 2 (VT2).
Unit 1	Step 1	<i>F900</i>	1	Reads IX1(F) terminal input signals. (LD IX1)
	Step 2	<i>F901</i>	4	ANDN command ( $IX1 \cap \overline{IX2}$ )
		<i>F902</i>	2	
	Step 3	<i>F903</i>	0 (Default)	NOP command (Disabling)
		<i>F904</i>	0 (Default)	
Step 4	<i>F905</i>	25	Incorporates the result into internal terminal 1. ( $IX1 \cap \Rightarrow IT1$ )	
Unit 2	Step 1	<i>F906</i>	2	Reads IX2(R) terminal input signals. (LD IX2)
	Step 2	<i>F907</i>	4	ANDN command ( $IX2 \cap \overline{IX1}$ )
		<i>F908</i>	1	
	Step 3	<i>F909</i>	5	OR command ( $(IX2 \cap \overline{IX1}) \cup IT1$ )
		<i>F910</i>	25	
Step 4	<i>F911</i>	21	Incorporates the result into virtual input terminal 1. ( $(IX2 \cap \overline{IX1}) \cup IT1 \Rightarrow VT1$ )	
Unit 3	Step 1	<i>F912</i>	1	Reads IX1(F) terminal input signals. (LD IX1)
	Step 2	<i>F913</i>	3	AND command ( $IX1 \cap IX2$ )
		<i>F914</i>	2	
	Step 3	<i>F915</i>	0 (Default)	NOP command (Disabling)
		<i>F916</i>	0 (Default)	
Step 4	<i>F917</i>	22	Incorporates the result into virtual input terminal 2. ( $IX2 \cap IX1 \Rightarrow VT2$ )	
-	-	<i>F977</i>	2	After setting all the above parameters, set this parameter to 2 to enable My function.

In this example, the number of steps can be reduced by using an NEQ (mismatch) command. That is, if the inverter is programmed so that it will issue a forward run command when the signal to input terminal 1 and the signal to input terminal 2 do not match (mismatch), the above units 1 and 2 can be combined into one (unit 1 shown below).

		Title	Parameter setting	Description
Unit 1	Step 1	F900	1	Reads IX1(F) terminal input signals. (LD IX1)
	Step 2	F901	8	NEQ command $((IX1 \cap \overline{IX2}) \cup (\overline{IX1} \cap IX2))$
		F902	2	
	Step 3	F903	0 (Default)	NOP command (Disabling)
		F904	0 (Default)	
Step 4	F905	21	Incorporates the result into virtual input terminal 1. $((IX1 \cap \overline{IX2}) \cup (\overline{IX1} \cap IX2) \Rightarrow VT1)$	

«Example 5: Push type operation»

This operation requires the function of starting and stopping operation by simply issuing a forward run command or a stop command to an input terminal, respectively. For reverse run, the function must also be able to start operation by executing a single reverse run command. In addition to this function, self-holding switches are used for this operation.

Figure 5-7 illustrates a wiring diagram and a timing chart. Operation is performed under the control of trigger signals to the input terminals IX1 to IX3.

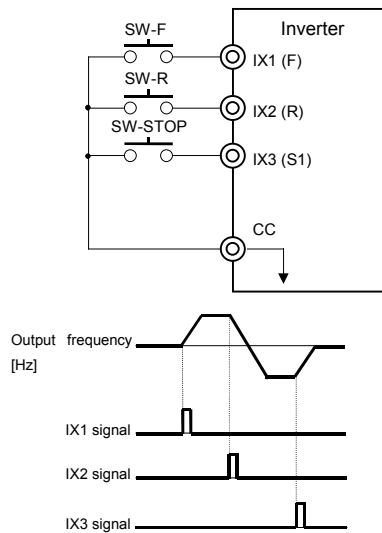
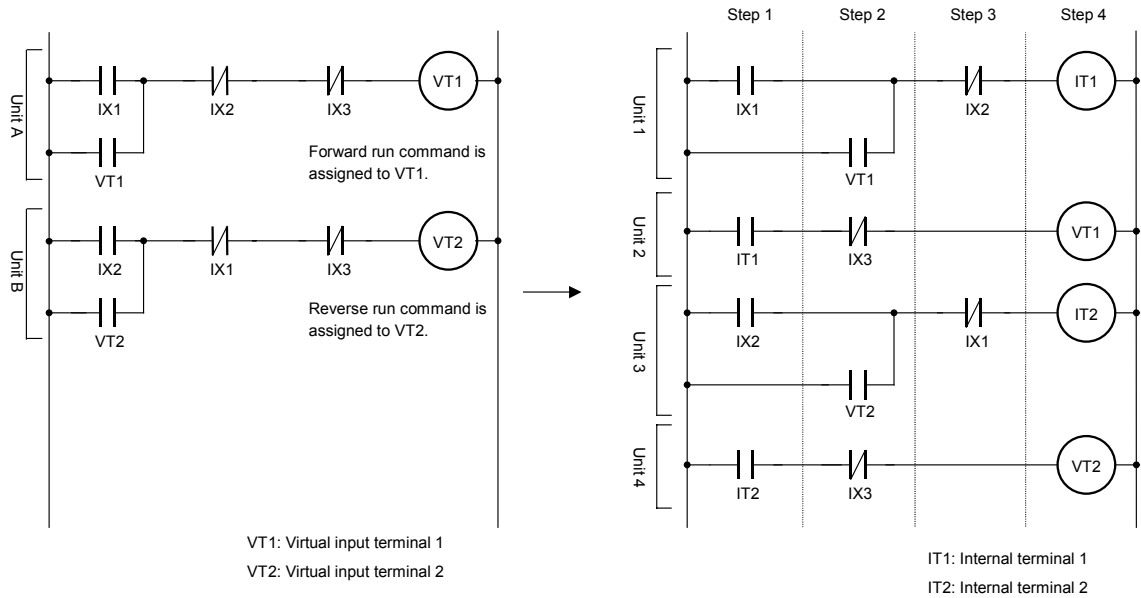

Fig. 5-7 Wiring diagram and timing chart for Example 5

To perform this function, a self-holding function (function of continuing operation by executing a single run command) is needed, as illustrated in the ladder diagram below. A forward run command and a reverse run command establish their respective self-holding circuits, and the self-holding circuit established by one of them is broken by the other or a stop command.



To set this function with My function, each unit (units A and B in the ladder diagram on the left), which consists of 5 steps, just as with the previous example, is divided, as illustrated in ladder diagram on the right, and changed to a unit consisting of 4 steps or less.

The above ladder diagram suggests that My function parameters listed in the table below need to be set.

		Title	Parameter setting	Description
Prior setting	-	F977	0 (Default)	Disables My function to prevent the system from starting accidentally during the setting of parameters.
		F111	0	Assigns no function to the F terminal (to use it as an input terminal (push type input terminal 1)).
		F112	0	Assigns no function to the R terminal (to use it as an input terminal (push type input terminal 2)).
		F115	0	Assigns no function to the S1 terminal (to use it as an input terminal (push type input terminal 3)).
		F973	2	Assigns the forward run command function to virtual input terminal 1 (VT1 = F command).
		F974	4	Assigns the reverse run command function to virtual input terminal 2 (VT2 = R command).
Unit 1	Step 1	F900	1	Reads IX1(F) terminal input signals. (LD IX1)
	Step 2	F901	5	OR command (IX1 ∪ VT1) self-holding circuit
		F902	2 1	
	Step 3	F903	4	ANDN command (IX1 ∪ VT1 ∩ $\overline{IX2}$ )
F904		2		
Step 4	F905	25	Incorporates the result into internal terminal 1. (IX1 ∪ VT1 ∩ $\overline{IX2}$ ⇒ IT1)	

		Title	Parameter setting	Description
Unit 2	Step 1	<i>F906</i>	<i>25</i>	Reads internal terminal 1 signals (LD IT1).
	Step 2	<i>F907</i>	<i>4</i>	ANDN command ( $IT1 \cap \overline{IX3}$ )
		<i>F908</i>	<i>5</i>	
	Step 3	<i>F909</i>	<i>0</i> (Default)	NOP command (Disabling)
<i>F910</i>		<i>0</i> (Default)		
Step 4	<i>F911</i>	<i>21</i>	Incorporates the result into virtual input terminal 1 to let it issue a forward run command. ( $IT1 \cap \overline{IX3} \Rightarrow VT1$ )	
Unit 3	Step 1	<i>F912</i>	<i>2</i>	Reads IX2(R) terminal input signals. (LD IX2)
	Step 2	<i>F913</i>	<i>5</i>	OR command ( $IX2 \cup VT2$ ) self-holding circuit
		<i>F914</i>	<i>22</i>	
	Step 3	<i>F915</i>	<i>4</i>	ANDN command ( $IX2 \cup VT2 \cap \overline{IX1}$ )
<i>F916</i>		<i>1</i>		
Step 4	<i>F917</i>	<i>26</i>	Incorporates the result into internal terminal 2 ( $IX2 \cup VT2 \cap \overline{IX1} \Rightarrow IT2$ )	
Unit 4	Step 1	<i>F935</i>	<i>26</i>	Reads internal terminal 2 signals (LD IT2)
	Step 2	<i>F936</i>	<i>4</i>	ANDN command ( $IT2 \cap \overline{IX3}$ )
		<i>F937</i>	<i>5</i>	
	Step 3	<i>F938</i>	<i>0</i> (Default)	NOP command (Disabling)
<i>F939</i>		<i>0</i> (Default)		
Step 4	<i>F940</i>	<i>21</i>	Incorporates the result into virtual input terminal 2 to let it issue a reverse run command. ( $IT2 \cap \overline{IX3} \Rightarrow VT2$ )	
-	-	<i>F977</i>	<i>2</i>	After setting all the above parameters, set this parameter to 2 to enable My function.

«Example 6: Operation with the automatic stop function»

This chapter explains how to set parameters for the relay sequence function described in Chapter 3.

This operation requires the function of receiving a push type signal, starting operation by issuing a forward run command, and stopping operation if the output current increases to 120% or more of the specified current when the operation frequency is 5Hz or less.

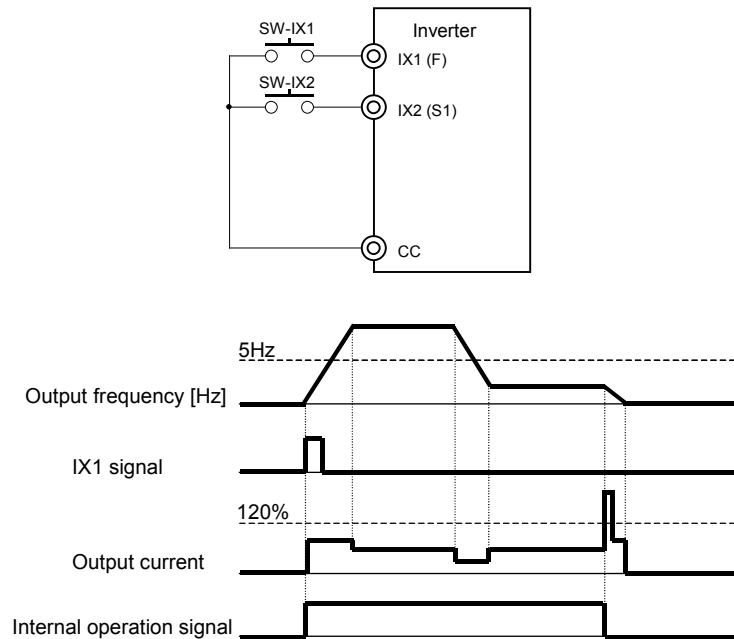
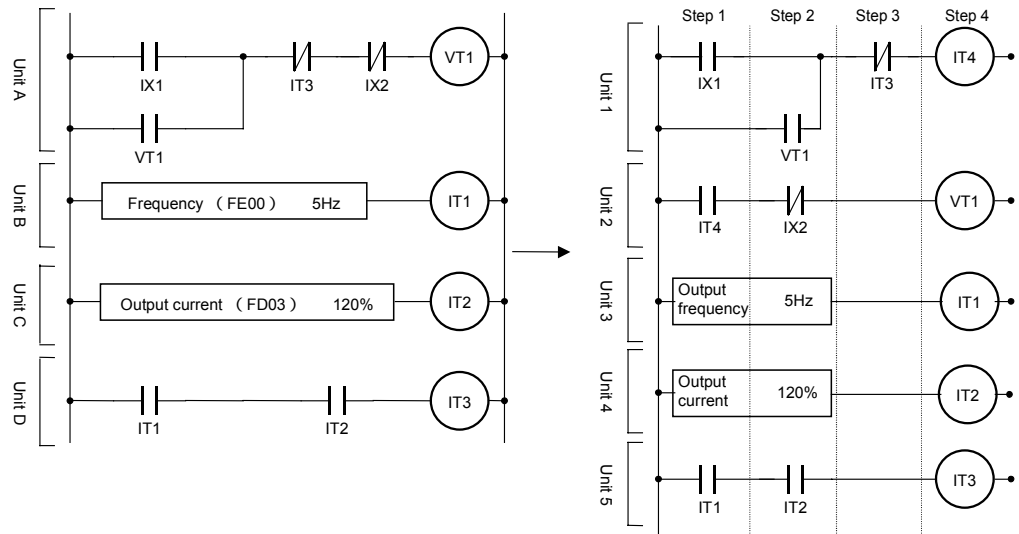

Fig. 5-7 Wiring diagram and timing chart for Example 6

- An input terminal is used as a terminal for issuing push type forward run commands (commands that are held effective once executed).
- Criteria for judging whether the operation frequency is 5Hz or below and whether the output current is 120% or less of the specified current are set with MY function.
- A program is written so that it will cancel a forward run command if both the above conditions are satisfied.
- Since the function of stopping operation forcibly is required, the program should be such that it will cancel a forward run command and stop operation if the S1 terminal receives even a single command.

These are illustrated in the ladder diagrams below.



VT1: Virtual input terminal (forward run command)      IT1: Internal terminal 1  
 IT2: Internal terminal 2  
 IT3: Internal terminal 3  
 IT4: Internal terminal 4

As unit A in the ladder diagram on the left consists of 5 steps, as with the previous example, it is divided and changed to a unit consisting of 4 steps or less, as illustrated in the ladder diagram on the right.

The above ladder diagrams suggest that My function parameters listed in the table below need to be set.

		Title	Parameter setting	Description
Prior setting	-	F977	0 (Default)	Disables My function to prevent the system from starting accidentally during the setting of parameters.
		F111	0	Assign no function to the F terminal to use it as an input terminal 1 (IX1) for issuing push type run commands.
		F115	0	Assign no function to the S1 terminal to use it as an input terminal 2 (IX2) for issuing push type stop commands.
		F918	120	Sets the limit at 120% to use it as a reference value when comparing and computing currents.
		F923	5	Sets the limit at 5Hz to use it as a reference value when comparing and computing frequencies.
		F973	2	Assigns the forward run command function to virtual input terminal 1 to let it issue a forward run command when it is turned on.



		Title	Parameter setting	Description
Unit 1	Step 1	F900	1	Reads IX1(F) terminal input signals (LD IX1)
	Step 2	F901	5	OR command (IX1 $\cup$ VT1)
		F902	25	
	Step 3	F903	4	ANDN command (IX1 $\cup$ VT1 $\cap$ $\overline{IT3}$ )
F904		27		
Step 4	F905	28	Incorporates the result into internal terminal 4 (IX1 $\cup$ VT1 $\cap$ $\overline{IT3} \Rightarrow IT4$ )	
Unit 2	Step 1	F906	28	Reads internal terminal 4 signals (LD IT4)
	Step 2	F907	4	ANDN command (IT4 $\cap$ $\overline{IX2}$ )
		F908	5	
	Step 3	F909	0 (Default)	NOP command (Disabling)
F910		0 (Default)		
Step 4	F911	21	Incorporates the result into VT1. (IT4 $\cap$ $\overline{IX2} \Rightarrow VT1$ )	
Unit 3	Step 1	F912	3000	Reads output frequency (LD Output frequency)
	Step 2	F913	12	LE command (Comparison to a frequency of 5Hz)
		F914	923	
	Step 3	F915	0 (Default)	NOP command (Disabling)
F916		0 (Default)		
Step 4	F917	25	Incorporates the result into internal terminal 1 (Comparison to a frequency of 5Hz $\Rightarrow IT1$ )	
Unit 4	Step 1	F935	2003	Reads output frequency (LD Output current)
	Step 2	F936	10	GE command (Comparison to 120%)
		F937	918	
	Step 3	F938	0 (Default)	NOP command (Disabling)
F939		0 (Default)		
Step 4	F940	26	Incorporates the result into internal terminal 2 (Comparison to 120% $\Rightarrow IT2$ )	
Unit 5	Step 1	F941	25	Reads internal terminal 1 signals (LD IT1)
	Step 2	F942	3	AND command (IT1 $\cap$ IT2)
		F943	26	
	Step 3	F944	0 (Default)	NOP command (Disabling)
F945		0 (Default)		
Step 4	F946	27	Incorporates the result into internal terminal 3 (IT1 $\cap$ IT2 $\Rightarrow IT3$ )	
-	-	F977	2	After setting all the above parameters, set this parameter to 2 to enable My function.

## 6. Analog input My function

The control panel is usually used to set parameters, but the analog input My function allows specific parameters and functions to be set continuously using an external control device.

The figure below illustrates an inverter that sets the upper-limit frequency ( $f_{UL}$ ) by means of analog signals.

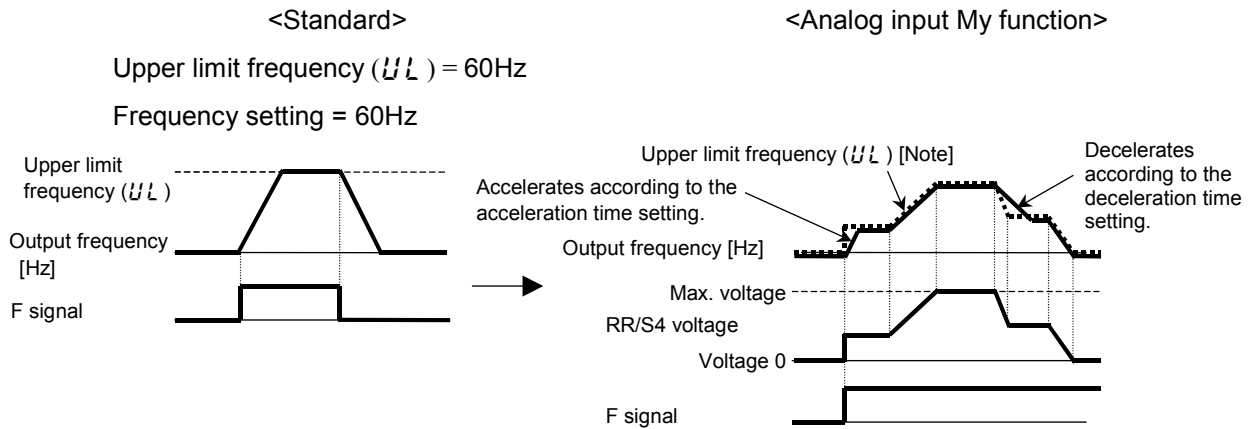
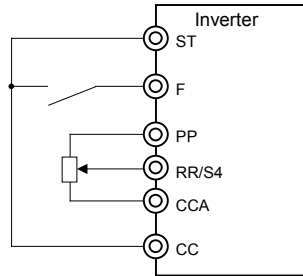

Note: Adjustments are made by the inverter itself, so no changes are made to parameter settings.

The acceleration and deceleration time can be adjusted by changing the analog input value to the RR/S4 terminal. The analog input My function is applicable to the 9 objects in  $F951$  and  $F954$  (object for which analog function is used) of the table below. Terminals to which the analog input My function is assigned can be specified with the parameters  $F959$  and  $F962$  (object to which analog input function is assigned).

■ **Parameters used**

Title	Function	Adjustment range	Default setting
<i>F 959</i>	Analog input function target 11	<i>0</i> : Deselect <i>1</i> : VI/II <i>2</i> : RR/S4 <i>3</i> : RX <i>4</i> : Optional AI1+, Optional AI1- <i>5</i> : Optional AI2	<i>0</i>
<i>F 961</i>	Analog function assigned object 11	<i>0</i> : Disabled <i>1</i> : Acceleration rate <i>2</i> : Upper limit frequency ( <i>UL</i> ) <i>3</i> : Acceleration multiplication factor <i>4</i> : Deceleration multiplication factor <i>5</i> : Manual torque boost ( <i>ub</i> ) <i>6</i> : OC stall ( <i>F 501</i> ) <i>7</i> : Thermal protection ( <i>t Hr</i> ) <i>8</i> : Speed loop P gain ( <i>F 450</i> ) <i>9</i> : Drooping gain ( <i>F 320</i> ) <i>10</i> : PID P gain ( <i>F 352</i> )	<i>0</i>
<i>F 962</i>	Analog input function target 21	Same as <i>F 959</i>	<i>0</i>
<i>F 964</i>	Analog function assigned object 21	Same as <i>F 961</i>	<i>0</i>

The analog input My function can be set in two ways.

If the analog input value specified with *F 959* is set so as to vary from 0 to the maximum value, the parameter for the object selected with *F 961* can be adjusted within a range of 0 to parameter setting \* variable factor. The same goes for *F 962* and *F 964*.

This analog value adjustment range can be adjusted by changing input points (F201 to F203, AIF2, F212 to F231, and AvF2) and the maximum frequency setting.

To be more specific, if the analog input voltage varies from 0 to 10V, the value set with the parameter *F 961* changes by a factor of:

$$\frac{F1}{FH} \text{ to } \frac{F2}{FH}$$

Where, FH is the maximum frequency (Hz), F1 is the frequency (Hz) at 0V, and F2 is the frequency (Hz) at 10V.

**Option 1: Acceleration/deceleration rate**

This option allows the acceleration/deceleration rate to change in proportion to the analog input value.

An example of using the RR/S4 terminal is given below.

*F H = 80* (Sets the maximum frequency at 80Hz.)

*F 959=2* (Selects the RR/S4 terminal.)

*F 961=1* (Selects acceleration/deceleration rate.)

*F 210=0* (Selects 0%.)

*F 211=20.0* (Selects 20Hz.)

$F212=100$  (Selects 100%)

$RUF2=80.0$  (Selects 80Hz.)

$$0V \quad \text{acceleration/deceleration rate} = \frac{20 \text{ (Hz)}}{80 \text{ (Hz)}} = 0.25$$

$$10V \quad \text{acceleration/deceleration rate} = \frac{80 \text{ (Hz)}}{80 \text{ (Hz)}} = 1.00$$

If the RR/S4 input value varies from 0 to the maximum value, the acceleration/deceleration rate changes by a factor of 0.25 to 1.

Note: A decrease in acceleration/deceleration rate by a factor of 0.25 means that the time elapsing before the completion of acceleration or deceleration increases by a factor of 4.

### Option 2: Upper-limit frequency (UL)

This option allows the upper-limit frequency (UL) to change in proportion to the analog input value.

The settings to be made are the same as those for option 1: acceleration/deceleration rate. In this example, if  $F961$  is set to 2 (upper-limit frequency), the upper-limit frequency set with the parameter UL changes by a factor of 0.25 to 1 according to the RR/S4 input value (0 to maximum value).

### Option 3: Acceleration multiplication factor

The acceleration time is determined by multiplying acceleration time 1 to acceleration time 4 (ACC, F500, F510 and F514) by the factor that varies with the analog input value.

The settings to be made are the same as those for option 1: acceleration/deceleration rate. In this example, if  $F961$  is set to 3 (acceleration multiplication factor (ACC)), acceleration time 1 to acceleration time 4 set with the parameters ACC, F500, F510 and F514, respectively, change by a factor of 0.25 to 1 according to the RR/S4 input value (0 to maximum value).

### Option 4: Deceleration multiplication factor

The deceleration multiplication factor has the same function as the acceleration multiplication factor described above. It is used with deceleration time 1 to deceleration time 4 (DEC, F501, F511 and F515).

### Option 5: Manual torque boost (ub)

This option allows the amount of boosted torque (ub) to change in proportion to the analog input value.

The settings to be made are the same as those for option 1: acceleration/deceleration rate. In this example, if  $F961$  is set to 5 (manual torque boost (ub)), the amount of manually boosted torque ub changes by a factor of 0.25 to 1 according to the RR/S4 input value (0 to maximum value).

### Option 6: OC stall (F601)

This option allows the stall prevention level (F601) to change in proportion to the analog input value.

The settings to be made are the same as those for option 1: acceleration/deceleration rate. In this example, if  $F961$  is set to 6 (OC stall (F601)), the OC stall value set with F601

changes by a factor of 0.25 to 1 according to the RR/S4 input value (0 to maximum value).

**Option 7: Electronic thermal ( $\xi Hr$ )**

This option allows the electronic thermal value ( $\xi Hr$ ) to change in proportion to the analog input value.

The settings to be made are the same as those for option 1: acceleration/deceleration rate. In this example, if  $F951$  is set to 7 (electronic thermal ( $\xi Hr$ )), the electronic thermal value set with the parameter  $\xi Hr$  changes by a factor of 0.25 to 1 according to the RR/S4 input value (0 to maximum value).

**Option 8: Speed loop P gain ( $F450$ )**

This option allows the speed loop P gain ( $F450$ ) to change in proportion to the analog input value.

The settings to be made are the same as those for option 1: acceleration/deceleration rate. In this example, if  $F951$  is set to 8 (speed loop P gain ( $F450$ )), the speed loop P gain set with  $F450$  changes by a factor of 0.25 to 1 according to the RR/S4 input value (0 to maximum value).

**Option 9: Drooping gain ( $F320$ )**

This option allows the droop gain ( $F320$ ) to change in proportion to the analog input value.

The settings to be made are the same as those for option 1: acceleration/deceleration rate. In this example, if  $F951$  is set to 9 (droop gain ( $F320$ )), the droop gain set with  $F320$  changes by a factor of 0.25 to 1 according to the RR/S4 input value (0 to maximum value).

**Option 10: PID P gain ( $F352$ )**

This option allows the PID P gain ( $F352$ ) to change in proportion to the analog input value.

The settings to be made are the same as those for option 1: acceleration/deceleration rate. In this example, if  $F951$  is set to 10 (PID P gain ( $F352$ )), the PID P gain set with  $F352$  changes by a factor of 0.25 to 1 according to the RR/S4 input value (0 to maximum value).

## 7. Analog output My function

This function puts out a parameter set value monitored, its peak value and minimum value through an analog output terminal. This function lets you know mainly the maximum and minimum values in a given period of time.

■ **Parameters used**

Title	Function	Adjustment range	Default setting
<i>F965</i>	Monitor output function target 11	<i>2000~2099</i> : FD00~FD99 (Note 1) <i>3000~3099</i> : FE00~FE99 (Note 1)	<i>2000</i>
<i>F966</i>	Monitor output function command 11	<i>0</i> : Normal monitor <i>1</i> : Max. value <i>2</i> : Min. value	<i>0</i>
<i>F967</i>	Monitor output function target 21	<i>2000~2099</i> : FD00~FD99 (Note 1) <i>3000~3099</i> : FE00~FE99 (Note 1)	<i>2000</i>
<i>F968</i>	Monitor output function command 21	<i>0</i> : Normal monitor <i>1</i> : Max. value <i>2</i> : Min. value	<i>0</i>
<i>F969</i>	Monitor output function target 31	<i>2000~2099</i> : FD00~FD99 (Note 1) <i>3000~3099</i> : FE00~FE99 (Note 1)	<i>2000</i>
<i>F970</i>	Monitor output function command 31	<i>0</i> : Normal monitor <i>1</i> : Max. value <i>2</i> : Min. value	<i>0</i>
<i>F971</i>	Monitor output function target 41	<i>2000~2099</i> : FD00~FD99 (Note 1) <i>3000~3099</i> : FE00~FE99 (Note 1)	<i>2000</i>
<i>F972</i>	Monitor output function command 41	<i>0</i> : Normal monitor <i>1</i> : Max. value <i>2</i> : Min. value	<i>0</i>

Note 1: See Table 8-7 "Data that My function can handle" in Appendix 5.

## Appendix 1 Table of My function parameters

The table below lists the parameters used for My function.

Table 8-1 Table of My function parameters

Title	Function	Adjustment range	Default setting
<i>F 900</i>	Input function target 11	Input terminal number <i>0</i> : Deselect <i>1</i> : F terminal <i>2</i> : R terminal <i>3</i> : ST terminal <i>4</i> : RES terminal <i>5</i> : S1 terminal <i>6</i> : S2 terminal <i>7</i> : S3 terminal <i>8</i> : RR/S4 terminal <i>9</i> : LI1 terminal <i>10</i> : LI2 terminal <i>11</i> : LI3 terminal <i>12</i> : LI4 terminal <i>13</i> : LI5 terminal <i>14</i> : LI6 terminal <i>15</i> : LI7 terminal <i>16</i> : LI8 terminal <i>17</i> : B12 terminal <i>18</i> : B13 terminal <i>19</i> : B14 terminal <i>20</i> : B15 terminal <i>21</i> : Virtual input terminal 1 <i>22</i> : Virtual input terminal 2 <i>23</i> : Virtual input terminal 3 <i>24</i> : Virtual input terminal 4 <i>25~32</i> : Internal terminal 1~8 <i>918~934</i> : My output data No. <i>1000~1255</i> : Output selection number (Note 1) <i>2000~2099</i> : FD00~FD99 (Note 2) <i>3000~3099</i> : FE00~FE99 (Note 2)	<i>0</i>
<i>F 901</i>	Input function command 12	<i>0</i> : NOP (disabling) <i>1</i> : ST (move) <i>2</i> : STN (move (inversion)) <i>3</i> : AND (logical product (A B)) <i>4</i> : ANDN (logical product (A B)) <i>5</i> : OR (logical sum (A B)) <i>6</i> : ORN (logical sum (A B)) <i>7</i> : EQ (equal) <i>8</i> : NE (not equal) <i>9</i> : GT (greater than) <i>10</i> : GE (greater or equal) <i>11</i> : LT (less than) <i>12</i> : LE (less or equal) <i>13</i> : ASUB (absolute) <i>14</i> : ON (on delay timer) <i>15</i> : OFF (off delay timer) <i>16</i> : COUNT1 (counter 1) <i>17</i> : COUNT2 (counter 2) <i>18</i> : HOLD (hold) <i>19</i> : SET (set) <i>20</i> : RESET (reset)	<i>0</i>
<i>F 902</i>	Input function target 12	Same as <i>F 900</i>	<i>0</i>
<i>F 903</i>	Input function command 13	Same as <i>F 901</i>	<i>0</i>
<i>F 904</i>	Input function target 13	Same as <i>F 900</i>	<i>0</i>
<i>F 905</i>	Output function assigned object 1	Same as <i>F 900</i>	<i>0</i>

Note 1: See Table 8-6 "Output terminal functions" in Appendix 4.

Note 2: See Table 8-7 "Data that My function can handle" in Appendix 5.

Title	Function	Adjustment range	Default setting
F906	Input function target 21	Same as F900	0
F907	Input function command 22	Same as F901	0
F908	Input function target 22	Same as F900	0
F909	Input function command 23	Same as F901	0
F910	Input function target 23	Same as F900	0
F911	Output function assigned object 2	Same as F900	0
F912	Input function target 31	Same as F900	0
F913	Input function command 32	Same as F901	0
F914	Input function target 32	Same as F900	0
F915	Input function command 33	Same as F901	0
F916	Input function target 33	Same as F900	0
F917	Output function assigned object 3	Same as F900	0
F918	My output percent data 1	0.00~200.0%	0.00
F919	My output percent data 2	0.00~200.0%	0.00
F920	My output percent data 3	0.00~200.0%	0.00
F921	My output percent data 4	0.00~200.0%	0.00
F922	My output percent data 5	0.00~200.0%	0.00
F923	My output frequency data 1	0.0~500.0Hz	0.0
F924	My output frequency data 2	0.0~500.0Hz	0.0
F925	My output frequency data 3	0.0~500.0Hz	0.0
F926	My output frequency data 4	0.0~500.0Hz	0.0
F927	My output frequency data 5	0.0~500.0Hz	0.0
F928	My output time data 1	0.0~600.0s	0.01
F929	My output time data 2	0.0~600.0s	0.01
F930	My output time data 3	0.0~600.0s	0.01
F931	My output time data 4	0.0~600.0s	0.01
F932	My output time data 5	0.0~600.0s	0.01
F933	No. of times of My output data 1	0~9999 times	0
F934	No. of times of My output data 2	0~9999 times	0
F935	Input function target 41	Same as F900	0
F936	Input function command 42	Same as F901	0
F937	Input function target 42	Same as F900	0
F938	Input function command 43	Same as F901	0
F939	Input function target 43	Same as F900	0
F940	Output function assigned object 4	Same as F900	0
F941	Input function target 51	Same as F900	0
F942	Input function command 52	Same as F901	0
F943	Input function target 52	Same as F900	0
F944	Input function command 53	Same as F901	0
F945	Input function target 53	Same as F900	0
F946	Output function assigned object 5	Same as F900	0
F947	Input function target 61	Same as F900	0
F948	Input function command 62	Same as F901	0
F949	Input function target 62	Same as F900	0
F950	Input function command 63	Same as F901	0
F951	Input function target 63	Same as F900	0
F952	Output function assigned object 6	Same as F900	0
F953	Input function target 71	Same as F900	0
F954	Input function command 72	Same as F901	0
F955	Input function target 72	Same as F900	0
F956	Input function command 73	Same as F901	0
F957	Input function target 73	Same as F900	0
F958	Output function assigned object 7	Same as F900	0
F973	Virtual input terminal selection 1	0~135 (Note 1)	0
F974	Virtual input terminal selection 2	0~135	0
F975	Virtual input terminal selection 3	0~135	0
F976	Virtual input terminal selection 4	0~135	0
F977	My function selection	0: Deselect 1: My function + permission signal 2: My function always ON	0

Note 1: See Table 8-4 "Input terminal functions" in Appendix 3.



## Appendix 2 Computing functions

The table below lists the computing functions provided by My function.

Table 8-2 Computing functions

Input function command	Computation name	Function	Description
0	NOP	Disabling	Used to disable the unnecessary sections (columns) of My function program.
1	ST	Transfer	Used mainly to read data.
2	STN	Transfer (inversion)	Used mainly to invert data and read inverted data.
3	AND	Logical product	Logical product of data ( $A \cap B$ )
4	ANDN	Logical product (inversion of right side)	Logical product of data ( $A \cap \overline{B}$ )
5	OR	Logical sum	Logical product of data ( $A \cup B$ )
6	ORN	Logical sum (inversion of right side)	Logical product of data ( $A \cup \overline{B}$ )
7	EQ	Comparison of data for matching	Compare two pieces of data, and puts out a 1 if they match each other or a 0 if not.
8	NE	Comparison of data for mismatch	Compare two pieces of data, and puts out a 0 if they match each other or a 1 if not.
9	GT	Comparison of sizes ( $A > B$ )	Compares the sizes of two pieces of data ( $A\_GT\_B$ ), and puts out a 1 if A is larger than B ( $A > B$ ) or a 0 if A is equal to or smaller than B ( $A \leq B$ )
10	GE	Comparison of sizes ( $A \geq B$ )	Compares the sizes of two pieces of data ( $A\_GT\_B$ ), and puts out a 1 if A is equal to or larger than B ( $A \geq B$ ) or a 0 if A is smaller than B ( $A < B$ )
11	LT	Comparison of sizes ( $A < B$ )	Compares the sizes of two pieces of data ( $A\_GT\_B$ ), and puts out a 1 if A is smaller than B ( $A < B$ ) or a 0 if A is equal to or larger than B ( $A \geq B$ )
12	LE	Comparison of sizes ( $A \leq B$ )	Compares the sizes of two pieces of data ( $A\_GT\_B$ ), and puts out a 1 if A is equal to or smaller than B ( $A \leq B$ ) or a 0 if A is larger than B ( $A > B$ )
13	ASUB	Absolute value of difference	Puts out the absolute value of the difference between two pieces of data. $ A - B $
14 [Note 1]	ON (ON timer)	ON delay	Delays the timing of turning data ON by the time specified with $F928$ to $F932$ .
15 [Note 1]	OFF (ON timer)	OFF delay	Delays the timing of turning data OFF by the time specified with $F928$ to $F932$ .
16 [Note 1]	COUNT1 (ON timer)	Counter	Counts the number of input pulses (counts the number of rising edges) and puts out a 1 when the pulse count specified with $F933$ has been reached.
17 [Note 1]	COUNT2 (ON timer)	Counter	Counts the number of input pulses (counts the number of rising edges) and puts out a 1 when the pulse count specified with $F934$ has been reached.
18 [Note 1]	HOLD	Peak hold	Puts out the peak input value.
19 [Note 1]	SET	Set	Sets data.
20 [Note 1]	RESET	Reset	Resets data.

Note 1: For details of computing functions 14 to 20, see Appendix 6.

## Appendix 3 Input terminal function selection parameters

The table below lists the parameters used to select functions for 20 input terminals (including 4 virtual input terminals) and the functions available.

Table 8-3 Input terminal function selection parameters

Title	Communication No.	Function	Adjustment range (Note 1)	Default setting
<i>F 110</i>	0110	Always ON function selection 1	<i>0~135</i>	<i>0</i>
<i>F 111</i>	0111	Input terminal function selection 1 (F)	<i>0~135</i>	<i>2</i>
<i>F 112</i>	0112	Input terminal function selection 2 (R)	<i>0~135</i>	<i>4</i>
<i>F 113</i>	0113	Input terminal function selection 3 (ST)	<i>0~135</i>	<i>6</i>
<i>F 114</i>	0114	Input terminal function selection 4 (RES)	<i>0~135</i>	<i>8</i>
<i>F 115</i>	0115	Input terminal function selection 5 (S1)	<i>0~135</i>	<i>10</i>
<i>F 116</i>	0116	Input terminal function selection 6 (S2)	<i>0~135</i>	<i>12</i>
<i>F 117</i>	0117	Input terminal function selection 7 (S3)	<i>0~135</i>	<i>14</i>
<i>F 118</i>	0118	Input terminal function selection 8 (RR/S4)	<i>0~135</i>	<i>72</i>
<i>F 119</i>	0119	Input terminal function selection 9 (LI1)	<i>0~135</i>	<i>0</i>
<i>F 120</i>	0120	Input terminal function selection 10 (LI2)	<i>0~135</i>	<i>0</i>
<i>F 121</i>	0121	Input terminal selection 11 (LI3)	<i>0~135</i>	<i>0</i>
<i>F 122</i>	0122	Input terminal selection 12 (LI4)	<i>0~135</i>	<i>0</i>
<i>F 123</i>	0123	Input terminal selection 13 (LI5)	<i>0~135</i>	<i>0</i>
<i>F 124</i>	0124	Input terminal selection 14 (LI6)	<i>0~135</i>	<i>0</i>
<i>F 125</i>	0125	Input terminal selection 15 (LI7)	<i>0~135</i>	<i>0</i>
<i>F 126</i>	0126	Input terminal selection 16 (LI8)	<i>0~135</i>	<i>0</i>
<i>F 164</i>	0164	Input terminal selection 17(B12)	<i>0~135</i>	<i>0</i>
<i>F 165</i>	0165	Input terminal selection 18(B13)	<i>0~135</i>	<i>0</i>
<i>F 166</i>	0166	Input terminal selection 19(B14)	<i>0~135</i>	<i>0</i>
<i>F 167</i>	0167	Input terminal selection 20(B15)	<i>0~135</i>	<i>0</i>
<i>F 973</i>	0973	Virtual input terminal selection 1	<i>0~135</i>	<i>0</i>
<i>F 974</i>	0974	Virtual input terminal selection 2	<i>0~135</i>	<i>0</i>
<i>F 975</i>	0975	Virtual input terminal selection 3	<i>0~135</i>	<i>0</i>
<i>F 976</i>	0976	Virtual input terminal selection 4	<i>0~135</i>	<i>0</i>

Note 1: For an explanation of the adjustment range, see Table 8-4 "Input terminal functions."

Table 8-4 Input terminal functions

Parameter setting		Function	Parameter setting		Function
Positive logic	Negative logic		Positive logic	Negative logic	
0	1	No function is assigned	70	71	Servo lock signal
2	3	F: Forward run command	72	73	Simple positioning (positioning loop)
4	5	R: Reverse run command	74	75	Integrating wattmeter display clear
6	7	ST: Standby	76	77	Trace back trigger signal
8	9	RES: Reset	78	79	Light-load high-speed operation prohibitive signal
10	11	S1: Preset speed 1	80	81	No function assigned
12	13	S2: Preset speed 2	82	83	No function assigned
14	15	S3: Preset speed 3	84	85	No function assigned
16	17	S4: Preset speed 4	86	87	Binary data write
18	19	Jog run	88	89	Up/down frequency (up)
20	21	Emergency stop	90	91	Up/down frequency (down)
22	23	DC braking	92	93	Up/down frequency (clear)
24	25	Acceleration/deceleration switching 1	94	95	No function assigned
26	27	Acceleration/deceleration switching 2	96	97	No function assigned
28	29	V/f switching signal 1	98	99	Forward/reverse selection
30	31	V/f switching signal 2	100	101	Run/stop command
32	33	Torque limit switching signal 1	102	103	Commercial power/INV switching
34	35	Torque limit switching signal 2	104	105	Frequency reference priority switching
36	37	PID control OFF selection	106	107	VI/II terminal priority
38	39	Pattern operation group 1	108	109	Command terminal board priority
40	41	Pattern operation selection 2	110	111	Permission of parameter editing
42	43	Pattern operation continuation signal	112	113	Speed/Torque switching
44	45	Pattern operation trigger signal	114	115	No function assigned
46	47	External thermal error	116	117	No function assigned
48	49	Forced switching from communication to local	118	119	No function assigned
50	51	HD operation retention	120	121	No function assigned
52	53	PID differentiation/integration clear	122	123	Rapidest deceleration command
54	55	PID forward/reverse switching	124	125	Preliminary excitation
56	57	Forced continuous operation	126	127	Braking request
58	59	Specified speed operation	128	129	No function assigned
60	61	Acceleration/deceleration suspend signal	130	131	Brake answer back input
62	63	Power failure synchronized signal	132	133	No function assigned
64	65	My function RUN signal	134	135	Traverse permission signal
66	67	Auto-tuning signal			
68	69	Speed gain switching			

## Appendix 4 Output terminal function selection parameters

The table below lists the parameters used to select functions for 11 output terminals and the functions available.

Table 8-5 Output terminal function selection parameters

Title	Communication No.	Function	Adjustment range (Note 1)	Default setting
<i>F 130</i>	0130	Output terminal function selection 1 (OUT1)	<i>0~255</i>	4
<i>F 131</i>	0131	Output terminal function selection 2 (OUT2)	<i>0~255</i>	6
<i>F 132</i>	0132	Output terminal function selection 3 (FL)	<i>0~255</i>	10
<i>F 133</i>	0133	Output terminal function selection 4 (OUT3)	<i>0~255</i>	254
<i>F 134</i>	0134	Output terminal function selection 5 (OUT4)	<i>0~255</i>	254
<i>F 135</i>	0135	Output terminal function selection 6 (R1)	<i>0~255</i>	254
<i>F 136</i>	0136	Output terminal function selection 7 (OUT5)	<i>0~255</i>	254
<i>F 137</i>	0137	Output terminal function selection 8 (OUT6)	<i>0~255</i>	254
<i>F 138</i>	0138	Output terminal function selection 9 (R2)	<i>0~255</i>	254
<i>F 168</i>	0168	Output terminal function selection 10 (R3)	<i>0~255</i>	254
<i>F 169</i>	0169	Output terminal function selection 11 (R4)	<i>0~255</i>	254

Note 1: For an explanation of the adjustment range, see Table 8-6 “Output terminal functions.”

Table 8-6 Output terminal functions

When using My function, select functions from among the positive-logic options for the output terminal functions. Note that negative-logic settings cannot be used for the output terminals.

Input setting	Parameter setting	Function	Operation output specifications (in case of positive logic)
<i>1000</i>	<i>0</i>	Lower limit frequency (LL)	ON: The running frequency is equal to or higher than the setting of <i>LL</i> (Lower limit frequency) OFF: The running frequency is lower than the setting of <i>LL</i> .
<i>1002</i>	<i>2</i>	Upper limit frequency (UL)	ON: The running frequency is equal to or higher than the setting of <i>UL</i> (Upper limit frequency) OFF: The running frequency is lower than the setting of <i>UL</i> .
<i>1004</i>	<i>4</i>	Low-speed signal	ON: The running frequency is equal to or higher than the setting of <i>F 100</i> (low-speed signal output frequency) OFF: The running frequency is lower than the setting of <i>F 100</i> .
<i>1006</i>	<i>6</i>	Acceleration/deceleration completion	ON: The difference between the frequency command and the running frequency is within the setting of <i>F 102</i> . OFF: In acceleration or deceleration.
<i>1008</i>	<i>8</i>	Speed reach signal	ON: The running frequency is in the range of $F 101 \pm F 102$ . OFF: The running frequency is out of the range of $F 101 \pm F 102$ .
<i>1010</i>	<i>10</i>	Failure FL (All trips)	ON: Inverter is tripped. OFF: Inverter trip is canceled.
<i>1012</i>	<i>12</i>	Failure FL (Except EF, OCL)	ON: Inverter is tripped (except <i>EF</i> and <i>OCL</i> ) OFF: Inverter trip is canceled. (reset)
<i>1014</i>	<i>14</i>	Overcurrent (OC) pre-alarm	ON: Inverter output current is over the <i>F601</i> (Stall prevention level) set value. OFF: Inverter output current is under the <i>F601</i> .

Input setting	Parameter setting	Function	Operation output specifications (in case of positive logic)
1016	16	Inverter overload (OL1) pre-alarm	ON: A certain rate of inverter overload ( $OL1$ ) detection time is over. OFF: The detection time is within a certain limit.
1018	18	Motor overload (OL2) pre-alarm	ON: A certain rate of inverter overload ( $OL2$ ) detection time is over. OFF: The detection time is within a certain limit.
1020	20	Overheat pre-alarm	ON: The temperature of the cooling fin is 95°C or higher inside the inverter. OFF: The temperature drops to 90°C or lower after overheat pre-alarm was on.
1022	22	Overvoltage pre-alarm	Overvoltage control operation or PB operation in progress. ON: PB operation level + 3% (200V class: Approx. 370Vdc, 400V class :Approx. 740Vdc)
1024	24	Undervoltage in main circuit (MOFF) detection	ON: The main circuit voltage is lower than the main circuit undervoltage detection ( $MOFF$ ) level. (200V class: Approx. 170Vdc, 400V class: Approx. 340Vdc)
1026	26	Low current detection	ON: The state that inverter output current is $F611$ set value or larger continued more than $F612$ set value.
1028	28	Over-torque detection	ON: The state that torque component is $F616$ , $F617$ set value or larger continued more than $F618$ set value.
1030	30	Braking resistor overload pre-alarm	ON: A certain rate of braking resistor overload trip ( $OLr$ ) detection time is over. OFF: The detection time is within a certain limit.
1032	32	In emergency stop	ON: In emergency stop operation ( $E$ is indicated). OFF: The detection time is within a certain limit.
1034	34	In retry	ON: In retry operation ( $rtr$ is indicated). OFF: No retry operation is performed.
1036	36	Pattern operation switching output	ON: In normal operation or pattern operation has finished. OFF: In pattern operation.
1038	38	PID deviation limit	ON: PID deviation is in $F364$ or $F365$ set value.
1040	40	Run/Stop	ON: Running frequency is output or DC injection braking ( $db$ ) is performed.
1042	42	Serious failure (OCA, OCL, EF, phase failure, etc.)	ON: Serious failure ( $OCA$ , $OCL$ , $EF$ , phase failure, abnormal output, short-circuit) is detected. OFF: Inverter has recovered from serious failure. (Serious failure has been reset)
1044	44	Light failure (OL, OC1, 2, 3, OP)	ON: Light failure ( $OL$ , $OC1$ , $OC2$ , $OC3$ , $OP$ ) is detected. OFF: Inverter has recovered from light failure. (Light failure has been reset)
1046	46	Commercial power/inverter switching output 1	Refer to Section 6.19 in the VF-AS1 Instruction Manual.
1048	48	Commercial power/inverter switching output 2	Refer to Section 6.19 in the VF-AS1 Instruction Manual.
1050	50	Cooling fan ON/OFF	ON: Cooling fan is in operation. OFF: Cooling fan is off operation.
1052	52	In jogging operation (In jog run)	ON: In jog run OFF: In normal operation
1054	54	Operation panel/terminal board operation switching	ON: In operation by terminal board. OFF: In operation by operation panel.
1056	56	Cumulative operation time alarm	ON: Cumulative operation time is beyond the $F621$ set value. OFF: Cumulative operation time is less than the $F621$ set value.
1058	58	PROFIBUS/DeviceNet/CC-Link communication error	ON: Communication error occurred. OFF: Communication error is canceled (reset).

Input setting	Parameter setting	Function	Operation output specifications (in case of positive logic)
1060	60	Forward/reverse switching	OFF: In forward operation. ON: In reverse operation. (The last status is held while operation is suspended.)
1062	62	Ready for operation 1	ON: In operable status or operation can be started with frequency command input as an operation switching answer-back. OFF: In inoperable status.
1064	64	Ready for operation 2	ON: In operable status or operation can be started with ST and RUN signals and frequency command input. OFF: In inoperable status.
1068	68	Brake release (BR)	Output the braking signal according to the brake sequence.
1070	70	In (pre-)alarm status	ON: More than one of alarm, pre-alarm, undervoltage, low current over-torque, poor control power supply, PID deviation limit, abnormal frequency setting or torque limit have occurred or detected. OFF: All the alarms above are canceled.
1072	72	Forward speed limit (torque control)	ON: Forward operation speed is $F425$ set value or over. OFF: Forward operation speed is less than $F425$ set value.
1074	74	Reverse speed limit (torque control)	ON: Reverse operation speed is $F428$ set value or over. OFF: Reverse operation speed is less than $F428$ set value.
1076	76	Inverter healthy output	ON and OFF are alternately output at intervals of 1 second.
1078	78	RS485 communication error	ON: Communication error occurred. OFF: Communication error is canceled (reset).
1080	80	Error code output 1	Output the error code in 6-bit.
1082	82	Error code output 2	
1084	84	Error code output 3	
1086	86	Error code output 4	
1088	88	Error code output 5	
1090	90	Error code output 6	
1092	92	Specified data output 1	Output of the designated data in 7-bit.
1094	94	Specified data output 2	
1096	96	Specified data output 3	
1098	98	Specified data output 4	
1100	100	Specified data output 5	
1102	102	Specified data output 6	
1104	104	Specified data output 7	
1106	106	Light load output	ON: Load is equal to $F335$ ~ $F338$ set values or less.
1108	108	Heavy load output	ON: Load is larger than $F335$ ~ $F338$ set value.
1110	110	Positive torque limit	ON: Positive torque is over the positive torque limit level.
1112	112	Negative torque limit	ON: Negative torque is over the positive torque limit level.
1114	114	Output for external rush suppression relay	ON: External rush suppression relay is actuated.
1118	118	Completion of stop positioning	ON: Stop positioning has been completed.
1120	120	L-STOP	ON: Operation at the lower limit frequency is performed continuously.
1122	122	Power failure synchronized operation	ON: Power failure synchronized operation is performed.
1124	124	Traverse in progress	ON: Traverse operation is performed.
1126	126	Traverse deceleration in progress	ON: Traverse deceleration operation is performed.

Input setting	Parameter setting	Function	Operation output specifications (in case of positive logic)
1128	128	Part replacement alarm	Alarm: The time of replacement of parts is approaching.
1130	130	Over-torque pre-alarm	ON: Over-torque is detected.
1132	132	Frequency command 1/2 selection	ON: Frequency command selection 2 is selected.
1134	134	Failure FL (Except emergency stop)	ON: A trip other than emergency stop has occurred.
1222	222	My function output 1	ON: My function output 1 is ON.
1224	224	My function output 2	ON: My function output 2 is ON.
1226	226	My function output 3	ON: My function output 3 is ON.
1228	228	My function output 4	ON: My function output 4 is ON.
1230	230	My function output 5	ON: My function output 5 is ON.
1232	232	My function output 6	ON: My function output 6 is ON.
1234	234	My function output 7	ON: My function output 7 is ON.
1236	236	My function output 8	ON: My function output 8 is ON.
1238	238	My function output 9	ON: My function output 9 is ON.
1240	240	My function output 10	ON: My function output 10 is ON.
1242	242	My function output 11	ON: My function output 11 is ON.
1244	244	My function output 12	ON: My function output 12 is ON.
1246	246	My function output 13	ON: My function output 13 is ON.
1248	248	My function output 14	ON: My function output 14 is ON.
1250	250	My function output 15	ON: My function output 15 is ON.
1252	252	My function output 16	ON: My function output 16 is ON.
1254	254	Always OFF (for terminal signal tests)	Output signal always OFF

## Appendix 5 Internal data

The table below lists the internal data that My function can handle.

This data is not rewritable. It can be used only as input data for comparison and computation.

Table 8-7 Data that MY function can handle

	Input setting	Communication No.	Function	Unit (Communication)
Monitor display output value	3000	FE00	Output frequency	0.01Hz
	3002	FE02	Frequency command value	0.01Hz
	3003	FE03	Output current	0.01%
	3004	FE04	Input voltage (DC detection)	0.01%
	3005	FE05	Output voltage	0.01%
	3015	FE15	Compensated frequency	0.01Hz
	3016	FE16	Speed feedback (real-time value)(Note 1)	0.01Hz
	3017	FE17	Speed feedback (1-second filter)(Note 1)	0.01Hz
	3018	FE18	Torque (Note 4)	0.01%
	3019	FE19	Torque command (Note 4)	0.01%
	3020	FE20	Torque current (Note 4)	0.01%
	3021	FE21	Exciting current	0.01%
	3022	FE22	PID feedback value	0.01Hz
	3023	FE23	Motor overload factor (OL2 data)	0.01%
	3024	FE24	Inverter overload factor (OL1 data)	0.01%
	3025	FE25	Regenerative braking resistance overload factor (OLr data)	1%
	3028	FE28	Regenerative braking resistor load factor (% ED)	1%
	3029	FE29	Input power	0.01kW
	3030	FE30	Output power	0.01kW
	3031	FE31	Pattern operation group number	0.1
	3032	FE32	Remaining no. of cycles for which pattern operation is continued	1
	3033	FE33	Pattern operation preset speed numbers	1
	3034	FE34	Remaining time for which pattern operation is continued	0.1
	3035	FE35	RR/S4 input	(Note 2)
	3036	FE36	VI/II input	(Note 2)
	3037	FE37	RX input (Note 4)	(Note 2)
	3038	FE38	Optional AI1 input (Note 4)	(Note 3)
	3039	FE39	Optional AI2 input	(Note 3)
	3040	FE40	FM output	1
	3041	FE41	AM output	1
	3066	FE66	Attached to expansion I/O card 1 CPU version	-
	3067	FE67	Attached to expansion I/O card 2 CPU version	-
3076	FE76	Integral input power	0.01kW	
3077	FE77	Integral output power	0.01kW	
3084	FE84	16-bit BIN/BCD input value	1	

Note 1: If there is no PG feedback, an estimated speed is displayed. If a PG feedback option is used as a pulse command input device, the frequency equivalent to the speed is displayed.

Note 2: The actual analog input value is the analog input value × monitored value/2047.

Note 3: The actual analog input value is the analog input value × monitored value/1023.

Note 4: If the value is negative, it should be converted into an absolute value, because My function cannot handle negative values correctly.



	Input setting	Communication No.	Function	Unit (Communication)	
FM/AM output Pulse output	<i>2000</i>	FD00	Output frequency	0.01Hz	
	<i>2002</i>	FD02	Frequency command value	0.01Hz	
	<i>2003</i>	FD03	Output current	0.01%	
	<i>2004</i>	FD04	Input voltage (DC detection)	0.01%	
	<i>2005</i>	FD05	Output voltage	0.01%	
	<i>2015</i>	FD15	Compensated frequency	0.01Hz	
	<i>2016</i>	FD16	Speed feedback (real-time value)(Note 1)	0.01Hz	
	<i>2017</i>	FD17	Speed feedback (1-second filter)(Note 1)	0.01Hz	
	<i>2018</i>	FD18	Torque (Note 2)	0.01%	
	<i>2019</i>	FD19	Torque command (Note 2)	0.01%	
	<i>2020</i>	FD20	Torque current (Note 2)	0.01%	
	<i>2021</i>	FD21	Exciting current	0.01%	
	<i>2022</i>	FD22	PID feedback value	0.01Hz	
	<i>2023</i>	FD23	Motor overload factor (OL2 data)	0.01%	
	<i>2024</i>	FD24	Inverter overload factor (OL1 data)	0.01%	
	<i>2025</i>	FD25	Regenerative braking resistance overload factor (OLr data)	1%	
	<i>2028</i>	FD28	Regenerative braking resistor load factor (% ED)	1%	
	<i>2029</i>	FD29	Input power	0.01kW	
	<i>2030</i>	FD30	Output power	0.01kW	
	<i>2050</i>	FD50	Light-load high-speed load torque monitor 1 (Note 2)	0.01%	
	<i>2051</i>	FD51	Light-load high-speed load torque monitor 2 (Note 2)	0.01%	
	<i>3050</i>	FE50	Communication data output 2	-	
	<i>3051</i>	FE51	Communication data output 1	-	
	<i>3052</i>	FE52	Communication data output 3	-	
	<i>3060</i>	FE60	My function monitor 1 (Output of unsigned value)	1	
	<i>3061</i>	FE61	My function monitor 2 (Output of unsigned value)	1	
	<i>3062</i>	FE62	My function monitor 3 (Output of signed value) (Note 2)	1	
<i>3063</i>	FE63	My function monitor 4 (Output of signed value) (Note 2)	1		

Note 1: If there is no PG feedback, an estimated speed is displayed. If used as pulse input command with PG feedback option, frequency is displayed as in the PG feedback.

Note 2: If the value is negative, it should be converted into an absolute value, because My function cannot handle negative values correctly.

## Appendix 6 Examples of computing function settings

Of the computing functions listed in Appendix 2, this chapter explains in detail the timer function, counter function, peak hold function, setting function and reset function and gives examples of their settings.

### ■ Input function command 14: ON (ON timer)

When the input signal is turned ON, this command delays the timing of putting out an ON signal by the time set for the ON timer, as shown in the figure below. The timer is turned on only when it receives an ON signal, as illustrated in the timing chart, so no ON signal is put out if the input signal ON time is shorter than the timer ON time (time during which the timer is activated). Conversely, when the input signal is turned OFF, an OFF signal is put out immediately and the timer is reset.

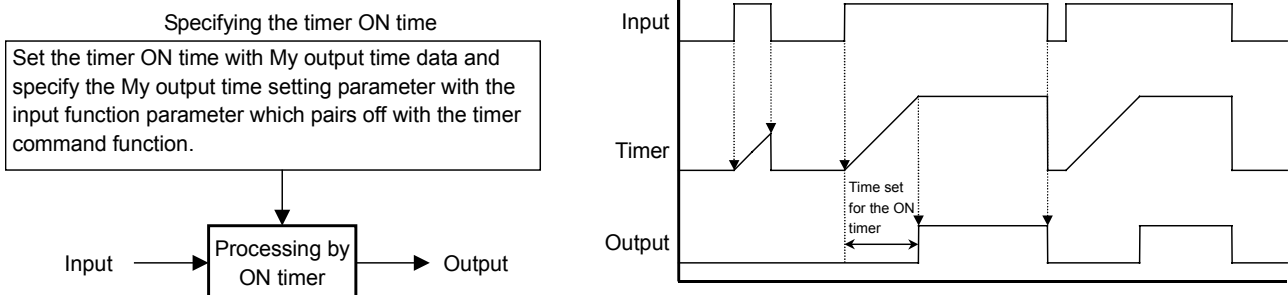

Fig. 8-1 Processing by ON timer

The table below shows an example of the setting to be made to send an ON signal from the S1 terminal to the OUT1 output terminal with a delay time (timer ON time) of 1 second.

		Title	Parameter setting	Description
Prior setting	-	F977	0 (Default)	Disables My function.
		F115	0	Assigns no function to the S1 terminal.
		F130	222	Assigns My function out 1 to the OUT1 output terminal.
		F928	1.0	Specify a delay time (timer ON time) of 1.0 second for My output time data 1.
Unit 1	Step 1	F900	5	Reads S1 terminal input signals.
	Step 2	F901	14	Activates the ON timer when the S1 terminal receives a signal.
		F902	928	Adjusts the setting of F928 to the timer ON time.
	Step 3	F903	0 (Default)	NOP command (Disabling)
		F904	0 (Default)	
Step 4	F905	1222	Incorporates the result into My function output 1.	
-	-	F977	2	Sets My function ON/OFF selection parameter to Always enabled.

■ Input function command 15: OFF (OFF timer)

When the input signal is turned OFF, this command delays the timing of putting out an OFF signal by the time set for the OFF timer, as shown in the figure below. The timer is activated only when it receives an OFF signal, as illustrated in the timing chart.

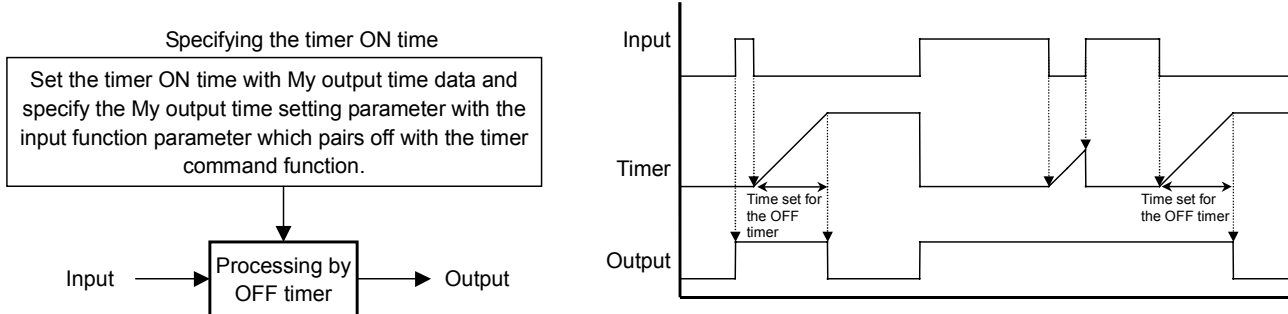

Fig. 8-2 Processing by OFF timer

The table below shows an example of the setting to be made to send an OFF signal from the S1 terminal to the OUT1 output terminal with a delay time (timer OFF time) of 1 second.

		Title	Parameter setting	Description
Prior setting	-	F 977	0 (Default)	Disables My function.
		F 115	0	Assigns no function to the S1 terminal.
		F 130	222	Assigns My function out 1 to the OUT1 output terminal.
		F 928	1.0	Specify a delay time (timer ON time) of 1.0 second for My output time data 1.
Unit 1	Step 1	F 900	5	Reads S1 terminal input signals.
	Step 2	F 901	15	Activates the OFF timer when the S1 terminal receives a signal.
		F 902	928	Adjusts the setting of F928 to the timer ON time.
	Step 3	F 903	0 (Default)	NOP command (Disabling)
		F 904	0 (Default)	
Step 4	F 905	1222	Incorporates the result into My function output 1.	
-	-	F 977	2	Sets My function ON/OFF selection parameter to Always enabled.

■ Input function command 16: Count 1 (counter)

This command makes the inverter count the number of times the input signal is turned on and off, as shown in the figure below, and put out a signal when the specified count has been reached. The count is reset to zero using the signal specified with the input function parameter which pairs off with the count command parameter. Note that this command has no relation to the set and reset commands described later.

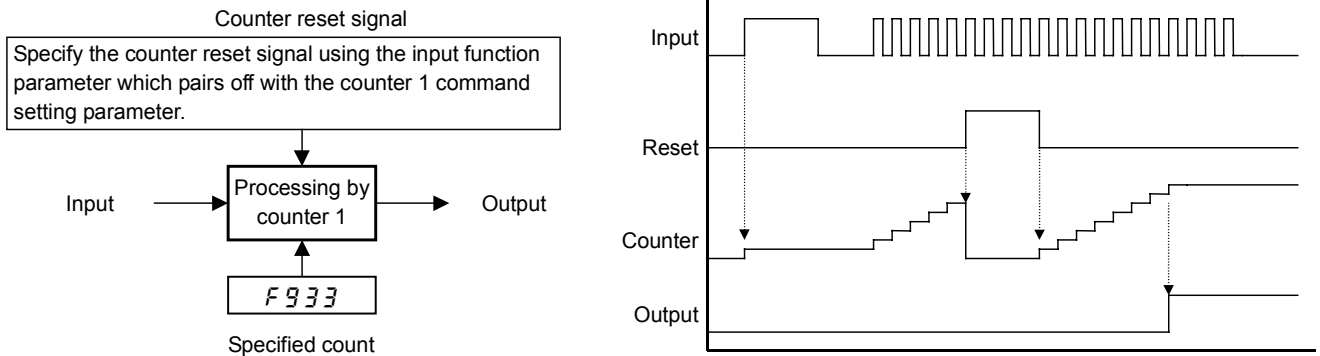

Fig. 8-3 Processing by counter

Note 1: Specify a pulse width of at least 5 ms for both ON and OFF pulse input signals.

Note 2: Reset commands have priority over count 1 commands. Therefore, if a reset command is entered the instant the specified count has been reached, the count is reset to zero and no signal is put out.

The table below shows an example of the setting to be made to send signals from the S1 terminal to the counter, to use signals from the S2 terminal as reset signals, and to put out a signal via the OUT1 output terminal when the count of 10 has been reached.

		Title	Parameter setting	Description
Prior setting	-	F977	0 (Default)	Disables My function.
		F115	0	Assigns no function to the S1 terminal.
		F116	0	Assigns no function to the S2 terminal.
		F130	222	Assigns My function out 1 to the OUT1 output terminal.
		F933	10	Specifies the count of 10 for Count 1.
Unit 1	Step 1	F900	5	Reads S1 terminal input signals.
	Step 2	F901	16	Counts the number of pulse signals to the S1 terminal.
		F902	6	Assigns the reset signal output function to the S2 terminal.
	Step 3	F903	0 (Default)	NOP command (Disabling)
		F904	0 (Default)	
Step 4	F905	1222	Incorporates the result into My function output 1.	
-	-	F977	2	Sets My function ON/OFF selection parameter to Always enabled.

Input function command 17 (Count 2 (counter)) has the same function as this command. For command 17, however, the parameter F934 is used to specify the count.

■ Input function command 18: Hold 1 (peak hold)

This command makes the inverter hold the peak value (usually, an analog values is used) of the input signal, as illustrated in the timing chart below.

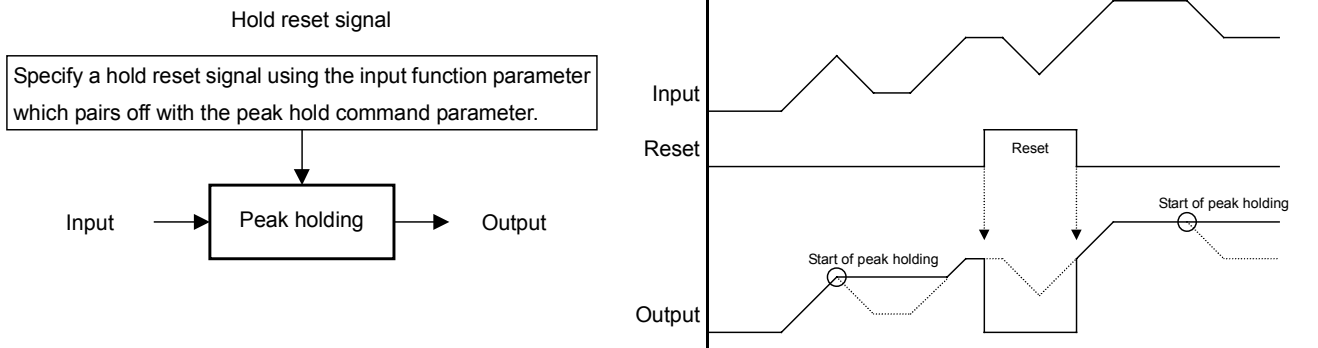

Fig. 8-4 Processing by peak hold

The table below shows an example of the setting to be made to hold the peak output current and to put out a signal via the OUT1 output terminal if the output current exceeds 120% of the specified current.

In this example, the count is reset to zero when a signal is received from the S1 terminal.

		Title	Parameter setting	Description
Prior setting	-	F977	0 (Default)	Disables My function.
		F115	0	Assigns no function to the S1 terminal.
		F130	222	Assigns My function out 1 to the OUT1 output terminal.
		F918	120	Assigns a reference value of 120% to My output percent data 1.
Unit 1	Step 1	F900	3003	Reads the output current.
	Step 2	F901	18	Starts holding the peak output current.
		F902	5	Assigns the reset signal output function to the S1 terminal.
	Step 3	F903	9	Puts out a signal if the peak value held reaches 120% of the specified value.
		F904	918	
Step 4	F905	1222	Incorporates the result into My function output 1.	
-	-	F977	2	Sets My function ON/OFF selection parameter to Always enabled.

■ Input function command 19: Set

■ Input function command 20: Reset

The set command turns on (sets) the output signal when the input signal is turned on, as shown in the figure below, and holds the output signal ON even after the input signal is turned off (reset). The reset command is used to turn off the output signal.

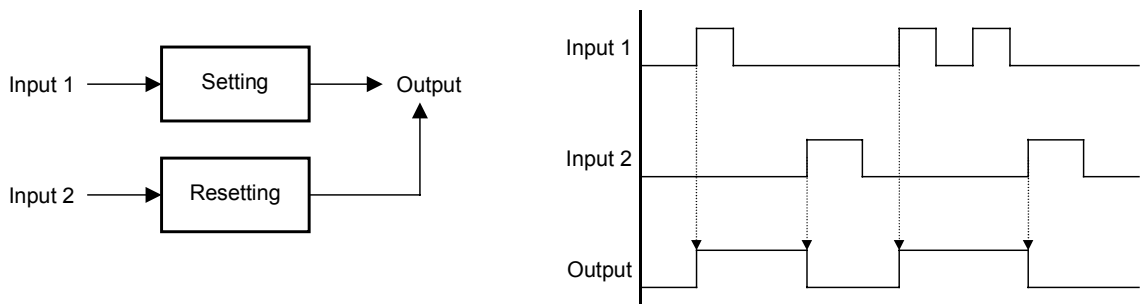

Fig. 8-5 Setting and resetting

Putting out a hold signal via the OUT1 output terminal when receiving a set command from the F input terminal.

Turning off (resetting) the output signal when receiving a signal from the S1 input terminal. The table below shows an example of the setting to be made for these operations.

		Title	Parameter setting	Description
Prior setting	-	F 977	0 (Default)	Disables My function.
		F 111	0	Assigns no function to the F terminal.
		F 115	0	Assigns no function to the S1 terminal.
		F 130	222	Assigns My function out 1 to the OUT1 output terminal.
Unit 1	Step 1	F 900	1	Reads signals to the F input terminal.
	Step 2	F 901	19	Sends a signal to My function output 1 when receiving a set command to put out a hold signal via the OUT1 terminal.
		F 902	1222	
	Step 3	F 903	0 (Default)	NOP command (Disabling)
		F 904	0 (Default)	
Step 4	F 905	0 (Default)	NOP command (Disabling)	
Unit 2	Step 1	F 906	5	Reads signals to the S1 input terminal.
	Step 2	F 907	20	Cancels the hold command from My function output 1 when receiving a reset command.
		F 908	1222	
	Step 3	F 909	0 (Default)	NOP command (Disabling)
		F 910	0 (Default)	
Step 4	F 911	0 (Default)	NOP command (Disabling)	
-	-	F 977	2	Sets My function ON/OFF selection parameter to Always enabled.