

TOSHIBA

Transistor Inverter

TOSVERT™ inverter dedicated to fan and pump for HVAC

VF-FS1



Three-phase 200V class 0.4kW to 30kW
Three-phase 400V class 0.4kW to 30kW

DREAM INVERTER dedicated to fan and pump for HVAC

SPACE SAVING, ECO-FRIENDLY, NOISE-LESS and LONG LIFE
The VF-FS1 provides these features as standard



Applications:
• AHUs
• Ventilation fans
• Chillers
• Water pumps
etc.

- POINT 1 → Half installation space and less wiring
- POINT 2 → Reactor-less harmonic reduction and high-frequency noise reduction
- POINT 3 → Long life and easy maintenance
- POINT 4 → Special softwares for fan and pump application are built-in
- POINT 5 → More energy saving and easier operation
- POINT 6 → Communications software and options

Totally enclosed box type for IP54



TOSVERT™ inverter dedicated to fan and pump for HVAC

VF-FS1

TOSVERT™ is a trademark of TOSHIBA Corporation.

Compatible with the World's Main Standards
 (CE marking, UL, CSA, C-tick)

ISO-9001 Certification Acquired
 This product is designed and manufactured in factories that have acquired certification of "ISO-9001", the international quality assurance standard.

ISO-14001 Certification Acquired
 The factories manufacturing this product are ISO-14001, environmental management system, registered factories.

Voltage class	Applicable Motor Output (kW)											
	0.4	0.75	1.5	2.2	3.7	5.5	7.5	11	15	18.5	22	30
3-phase 200V class (IP20/IP00)	[Pink bar indicating full range of motor outputs]											
3-phase 400V class (IP20/IP00)	[Grey bar indicating full range of motor outputs]											
3-phase 400V class (IP54)	[Blue bar indicating full range of motor outputs]											

Note: VF-FS1 is not applicable for apparatus which needs sudden deceleration and stop.

POINT 1 Half installation space and less wiring

Half installation space

Reactor-less harmonic suppress technologies and built-in filter reduce 50% of installation space, save time and cost of wiring.

And side-by-side installation realizes effective utilization of space in control panels.

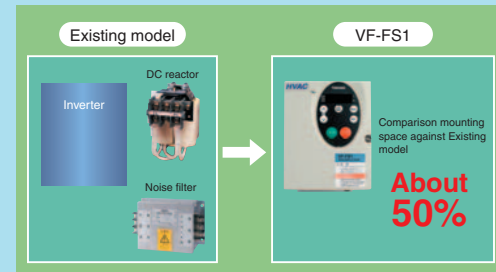

POINT 2 Reactor-less harmonics reduction and high-frequency noise reduction

Harmonics reduction, Power factor improvement

Toshiba unique technologies suppress harmonics, particularly 5th and 7th harmonic current that affect power sources. And the power factor in all models has been improved. Harmonics are controlled to within the Total Harmonic Distortion (THD) of international standard IEC61000-3-12 without any external reactor. ($R_{sc} \geq 120$)

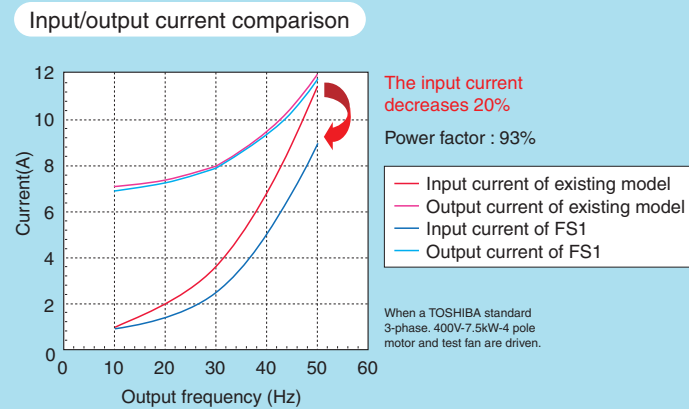
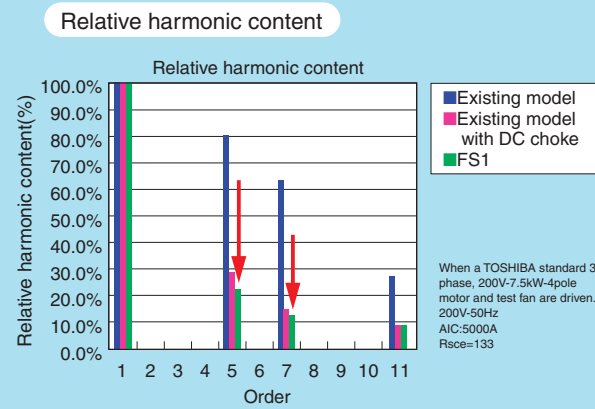

High-frequency noise reduction

High-frequency noise is drastically reduced on models with built-in noise filters. Built-in noise filters are ideal for office, commercial facilities, and factories where special attention for peripheral devices are needed.

Compared with existing model, less space and wiring are realized by incorporating filter in the panel. In addition, models with built-in EMC noise filter comply with the European EMC Directive as individual inverter units.

Built-in EMC filter



400V class models : EMI noise filter
(complies with the European EMC Directive) built-in standard

200V class models : Basic noise filter
(not complies with the European EMC Directive) built-in standard

Effect of built-in filter

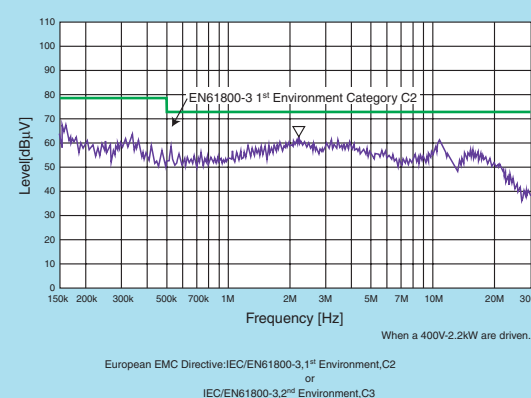

POINT 3 Long life and easy maintenance

Long life and easy maintenance

- 15 years life designed main capacitors
- An alarm warns when the main circuit capacitors, circuit boards capacitors, or cooling fan needs to be replaced.
- Cooling fan's On/Off control extend its life
- Easy replacement of cooling fan by one touch
- The inverter unit can be replaced by removable terminal block without disconnecting cables.

Long life main film capacitors

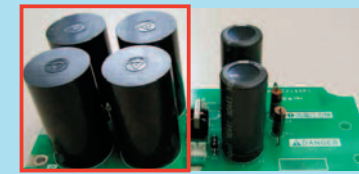

Cooling fan



Removable control terminal board

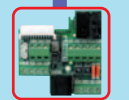
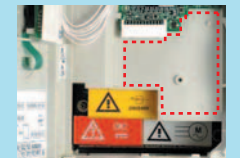

POINT 4 Special softwares for fan and pump application are built-in

Ideal functions are built-in for fan and pump application.

- The local or remote operation can be selected by one touch.
- Bumpless function realize seamless operation between local and remote.
- Fire control enables forced operation in emergency. In case of emergency, forced control will run by specified frequency. The forced operation signal will be saved when the signal turns ON. Motor does not stop in the event of the occurrence of a soft fault.
- Speed reference can manage on/off operation. (sleep function)
- Low current detection can notice a broken belt or low load for pump application
- PTC thermistor input
- Built-in RS485 (TOSHIBA/Modbus protocol) communication as standard. Optional fieldbuses for LonWorks®, BACnet®, Metasys®N2 and APOGEE® FLN as built in option.

Local/Remote key

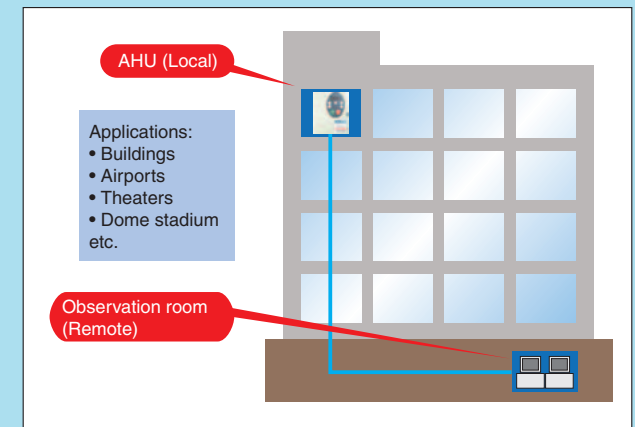

For exemplum : Fire control enables forced operation

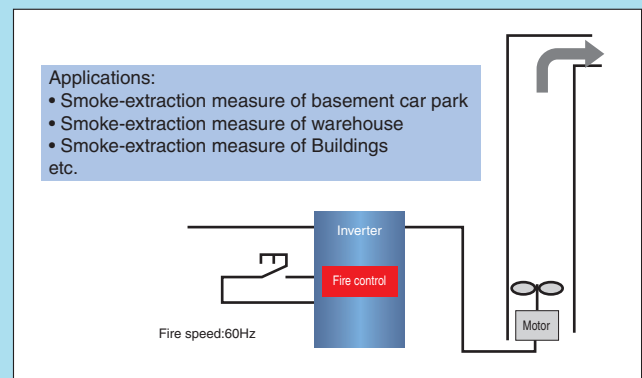

LonWorks® is a registered trademark of Echelon Corporation.
BACnet® is a registered trademark of American Society of Heating, Refrigerating and Air-Conditioning Engineers, Incorporated.
Metasys®N2 is a registered trademark of Johnson Controls, Incorporated.
APOGEE® FLN is a registered trademark of Siemens Building Technologies, Incorporated.

POINT 5 More energy saving and easier operation

More energy saving

The advanced energy-saving mode optimizes fan and pump efficiency even at normally inefficient in low speeds.

The effect can be monitored by operation panel or through serial communication data.

Monitor

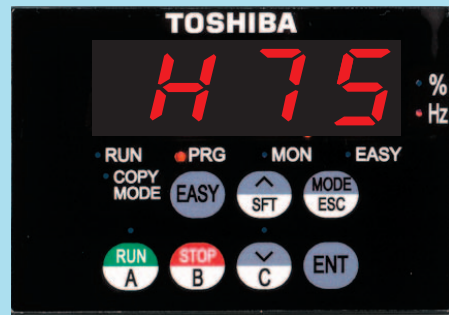

Effect of advanced energy-saving mode

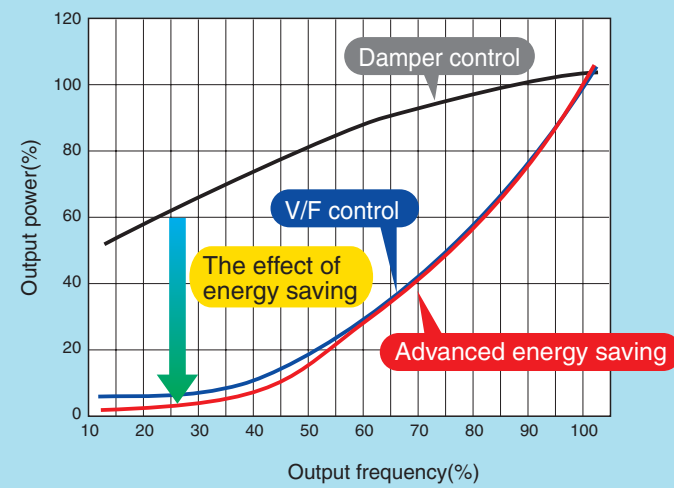

Output power	⊙	H 75	FE30	The inverter output power (kW) is displayed.
Integral output power	⊙	H 75	FE77	The integrated amount of power (kWh) supplied from the inverter is displayed.

Easy operation

A wizard function enable set the 10 most often used parameter quickly. It can be sequentially, such as installing the PC software.

Macro function for basic parameters by one setting is available as shown below.

- The coast stop
- The 3-wire operation
- External input UP/DOWN setting
- 4 to 20mA current input operation

The startup or adjustments are supported by the history function that displays the latest 5 changed parameters.

Quick setting wizard

Title	Function
<i>Aut</i>	Automatic acceleration/deceleration
<i>Acc</i>	Acceleration time 1
<i>Dec</i>	Deceleration time 1
<i>LL</i>	Lower limit frequency
<i>UL</i>	Upper limit frequency
<i>tHr</i>	Motor thermal protection
<i>Fn</i>	Meter adjustment
<i>Pt</i>	V/F control mode selection
<i>uL</i>	Base frequency 1
<i>uLv</i>	Base frequency voltage 1

POINT 6 Communications software and options

Communications software

The PCM001Z communications software allows you to edit, monitor, and trace parameter data on a PC. It realize easier data management for commissioning and maintenance.



Options

USB communications conversion unit

This is a unit which converts USB port signal to VF inverter serial port for data communication. Optional cables to USB and inverter unit are required. By using serial data communication, all parameters and monitoring data can be accessed for commissioning and maintenance.

USB communications conversion unit



Network

Built-in HVAC fieldbuses option are available to communicate with a host controller for centralized control.

- LonWorks®
- BACnet®
- Metasys® N2
- APOGEE® FLN

LonWorks® board



LED extension panel

The panel with 20 mm height LEDs displays frequency and parameters very clearly at sight. In addition, it can save and download up to three sets of individual parameters as a parameter writer.

LED extension panel



External EMC directive compliant noise reduction filter

It can be complied to the following directives by installing this filter

- 400V class: IEC/EN61800-3, 1st Environment, C1
or IEC/EN61800-3, 1st Environment, C2
- 200V class: IEC/EN61800-3, 1st Environment, C2
or IEC/EN61800-3, 2nd Environment, C3

External EMC directive compliant noise reduction filter



Standard Specifications

Standard specifications

200V class

Item	Specification												
Input voltage	3-phase 200V												
Applicable motor (kW)	0.4	0.75	1.5	2.2	3.7	5.5	7.5	11	15	18.5	22	30	
Rating	Type	VFFS1											
	Form	2004PM	2007PM	2015PM	2022PM	2037PM	2055PM	2075PM	2110PM	2150PM	2185PM	2220PM	2300PM
	Capacity (kVA) Note 1)	1.1	1.8	2.9	4.0	6.7	9.2	12.2	17.6	23.2	28.5	33.5	44.6
	Rated output/current (A) Note 2)	2.8	4.6	7.5	10.6	17.5	24.2	32	46.2	61	74.8 (67.3)	88.0 (79.2)	117.0 (105.3)
	Output voltage Note 3)	3-phase 200V to 240V											
Overload current rating	110%-60 seconds, 180%-2 second												
Power supply	Voltage-current	3-phase 200V to 240V -50/60Hz											
	Allowable fluctuation	Voltage +10%, -15% Note 4), frequency ±5%											
Protective method	IP20 Enclosed type (JEM1030)											IP00 Enclosed type (JEM1030) Note 5)	
Cooling method	Forced air-cooled												
Color	Munsel 5Y-8/0.5												
Built-in filter	Basic filter												

400V class

Item	Specification												
Input voltage	3-phase 400V												
Applicable motor (kW)	0.4	0.75	1.5	2.2	3.7	5.5	7.5	11	15	18.5	22	30	
Rating	Type	VFFS1											
	Form	4004PL	4007PL	4015PL	4022PL	4037PL	4055PL	4075PL	4110PL	4150PL	4185PL	4220PL	4300PL
	Capacity (kVA) Note 1)	1.1	1.6	2.8	3.9	6.9	9.1	12.2	17.1	23.2	28.2	33.2	44.6
	Rated output current (A) Note 2)	1.4	2.2	3.7	5.1	9.1	12.0	16.0	22.5	30.5	37.0 (33.3)	43.5 (39.2)	58.5 (52.7)
	Rated output voltage Note 3)	3-phase 380V to 480V											
Overload current rating	110%-60 seconds, 180% -2 second												
Power supply	Voltage-current	3-phase 380V to 480V - 50/60Hz											
	Allowable fluctuation	Voltage +10%, -15% Note 4), frequency ±5%											
Protective method,	IP20 Enclosed type (JEM1030)											IP00 Enclosed type (JEM1030) Note 5)	
Cooling method	Forced air-cooled												
Color	Munsel 5Y-8/0.5												
Built-in filter	EMI filter												

Note 1: Capacity is calculated at 220V for the 200V models, at 440V for the 400V models.
 Note 2: The rated output current in the parenthesis is at 12kHz of PWM carrier frequency (F300) setting.
 Note 3: Maximum output voltage is the same as the input voltage.
 Note 4: ±10% when the inverter is used continuously (load of 100%).
 Note 5: Inverter, 22kW or greater, do not have wiring port covers, they have large openings, but there is no space to bend the external cables inside the unit. If they are fitted external to the cabinet, please use an optional wiring port cover.

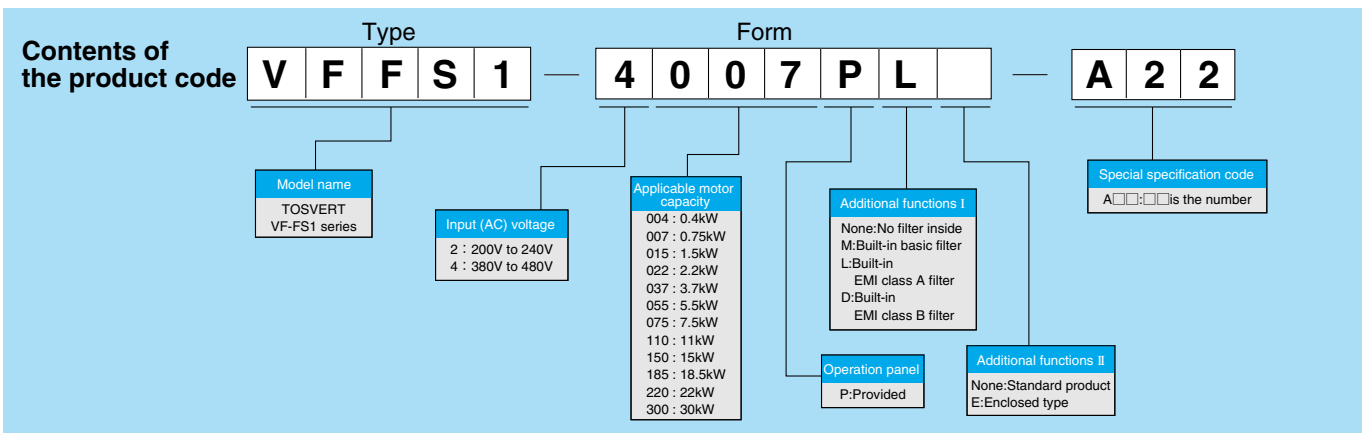

Common specifications

Item	Specification	
Principal control functions	Control system	Sinusoidal PWM control
	Output voltage adjustment	Adjustable within the range of 50 to 660V by correcting the supply voltage (not adjustable above the input voltage)
	Output frequency range	0.5 to 200.0Hz, default setting: 0.5 to 80Hz, maximum frequency: 30 to 200Hz
	Minimum setting steps of frequency	0.1Hz: analog input (when the max. frequency is 100Hz), 0.01Hz: Operation panel setting and communication setting.
	Frequency accuracy	Digital setting: within ±0.01% of the max. frequency (-10 to +60°C) Analog setting: within ±0.5% of the max. frequency (25°C ±10°C)
	Voltage/frequency characteristics	V/F constant, variable torque, automatic torque boost, vector control, automatic energy-saving, PM motor control. Auto-tuning. Base frequency (25 - 200Hz) adjusting to 1 or 2, torque boost (0 - 30%) adjusting to 1 or 2, adjusting frequency at start (0.5 - 10Hz)
	Frequency setting signal	External frequency potentiometer (connectable to a potentiometer with a rated impedance of 1 - 10kΩ), 0 - 10Vdc (input impedance: VIA/VIB=30kΩ, 4 - 20mAdc (Input impedance: 250Ω).
	Terminal board base frequency	The characteristic can be set arbitrarily by two-point setting. Possible to set individually for three functions: analog input (VIA and VIB) and communication command.
	Frequency jump	Three frequencies can be set. Setting of the jump frequency and the range.
	Upper- and lower-limit frequencies	Upper-limit frequency: 0 to max. frequency, lower-limit frequency: 0 to upper-limit frequency
PWM carrier frequency	Adjustable within a range of 6.0 to 16.0Hz (default: 8 or 12kHz).	
PID control	Setting of proportional gain, integral gain, differential gain and control wait time. Checking whether the amount of processing amount and the amount of feedback agree.	
Operation specifications	Acceleration/deceleration time	Selectable from among acceleration/deceleration times 1 and 2 (0.0 to 3200 sec.). Automatic acceleration/deceleration function. S-pattern acceleration/deceleration 1 and 2 and S-pattern adjustable. Control of forced rapid deceleration and dynamic rapid deceleration
	DC braking	Braking start-up frequency: 0 to maximum frequency, braking rate: 0 to 100%, braking time: 0 to 20 seconds, emergency DC braking
	Input terminal function (programmable)	Possible to select from among 57 functions, such as forward/reverse run signal input, operation base signal input and reset signal input, to assign to 4 input terminals. Logic selectable between sink and source.
	Output terminal functions (programmable)	Possible to select from among 58 functions, such as upper/lower limit frequency signal output, low speed detection signal output, specified speed reach signal output and failure signal output, to assign to FL relay output, RY output terminals.
	Forward/reverse run	The RUN and STOP keys on the operation panel are used to start and stop operation, respectively. The switching between forward run and reverse run can be done from one of the three control units: operation panel, terminal board and external control unit.
	Preset speed operation	Base frequency + 7-speed operation possible by changing the combination of 3 contacts on the terminal board.
	Retry operation	Capable of restarting automatically after a check of the main circuit elements in case the protective function is activated. 10 times (Max.) (selectable with a parameter)
	Various prohibition settings	Possible to write-protect parameters and to prohibit the change of panel frequency settings and the use of operation panel for operation, emergency stop or resetting.
	Auto-restart operation	In the event of a momentary power failure, the inverter reads the rotational speed of the coasting motor and outputs a frequency appropriate to the rotational speed in order to restart the motor smoothly. This function can also be used when switching to commercial power.
	Drrooping function	The motor is allowed to "slip" according to the load torque current.
Protective function	Failure detection signal	1c-contact output: (250Vac-0.5A-cosφ=0.4)
	Protective function	Stall prevention, current limitation, over-current, output short circuit, over-voltage, over-voltage limitation, undervoltage, ground fault, power supply phase failure, output phase failure, overload protection by electronic thermal function, armature over-current at start-up, load side over-current at start-up, over-torque, undercurrent, overheating, cumulative operation time, life alarm, emergency stop, various pre-alarms
	Electronic thermal characteristic	Switching between standard motor and constant-torque VF motor, switching between motors 1 and 2, setting of overload trip time, adjustment of stall prevention levels 1 and 2, selection of overload stall
	Reset function	Function of resetting by closing contact 1a or by turning off power or the operation panel. This function is also used to save and clear trip records.
Display function	Alarms	Stall prevention, overvoltage, overheating, short-circuit in load, ground fault, overload on inverter, over-current through arm at start-up, over-current through load at start-up, CPU fault, EEPROM fault, RAM fault, ROM fault, communication error. (Selectable: Emergency stop, under-voltage, low voltage, over-torque, motor overload, output open-phase)
	Causes of failures	Over-current, overvoltage, overheating, short-circuit in load, ground fault, overload on inverter, over-current through arm at start-up, over-current through load at start-up, CPU fault, EEPROM fault, RAM fault, ROM fault, communication error. (Selectable: Emergency stop, under-voltage, low voltage, over-torque, motor overload, output open-phase)
	Monitoring function	Operation frequency, operation frequency command, forward/reverse run, output current, voltage in DC section, output voltage, torque, torque current, load factor of inverter, input power, output power, information on input terminals, information on output terminals, version of CPU1, version of CPU2, version of memory, PID feedback amount, frequency command (after PID), integral input power, integral output power, rated current, output speed, communication counter, normal state communication counter, causes of past trips 1 through 4, parts replacement alarm, cumulative operation time
	Past trip monitoring function	Stores data on the past four trips: number of trips that occurred in succession, operation frequency, direction of rotation, load current, input voltage, output voltage, information on input terminals, information on output terminals, and cumulative operation time when each trip occurred.
	Output for frequency meter	Analog output: (1mAdc full-scale DC ammeter or 7.5Vdc full-scale DC ammeter/Rectifier-type AC voltmeter, 120% current Max. 1mAdc, 7.5Vdc full-scale), 4 to 20mA/0 to 20mA output
	4-digit 7-segments LED	Frequency: inverter output frequency. Alarm: stall alarm "C", overvoltage alarm "P", overload alarm "L", overheat alarm "H". Status: inverter status (frequency, cause of activation of protective function, input/output voltage, output current, etc.) and parameter settings. Free-unit display: arbitrary unit (e.g. rotating speed) corresponding to output frequency.
	Indicator	Lamps indicating the inverter status by lighting, such as RUN lamp, MON lamp, PRG lamp, % lamp, Hz lamp, LOC/REM key lamp, UP/DOWN key lamp and RUN key lamp. The charge lamp indicates that the main circuit capacitors are electrically charged.
Environments	Use environments	Indoor, altitude: 1000m (Max.), not exposed to direct sunlight, corrosive gas, explosive gas or vibration (less than 5.9m/s2) (10 to 55Hz)
	Ambient temperature	-10 to +60°C Note1) Note2)
	Storage temperature	-20 to +65°C
	Relative humidity	20 to 93% (free from condensation and vapor).

Note 1: Above 40°C: Remove the seal from the top of the inverter and use the inverter with the rated output current reduced.
 Note 2: If inverters are installed side by side (with no sufficient space left between them): Remove the seal from the top of each inverter.
 When installing the inverter where the ambient temperature will rise above 40°C, remove the seal from the top of the inverter and use the inverter with the rated output current reduced.

External dimension

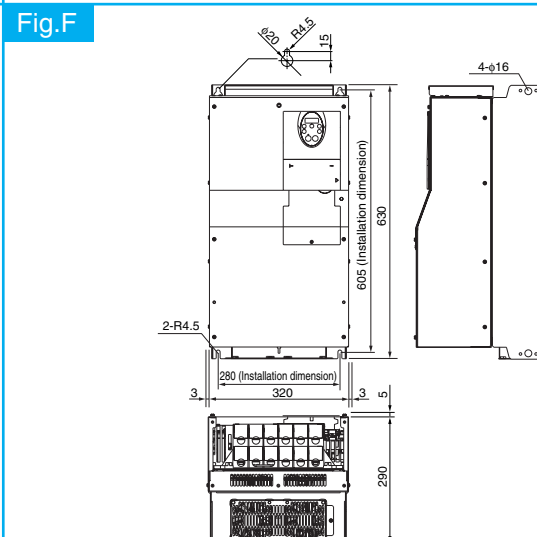
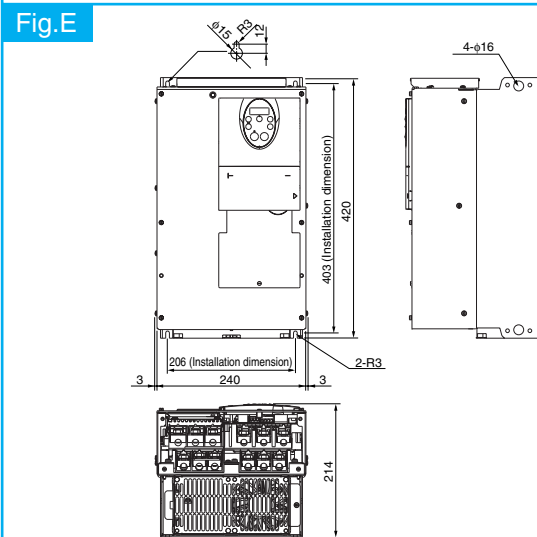
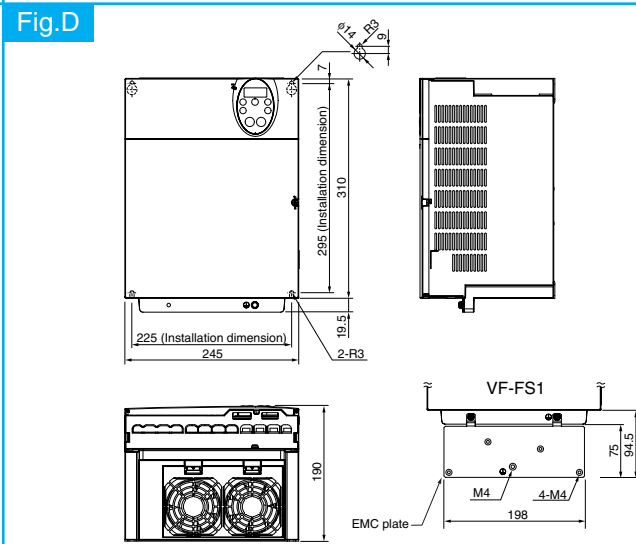
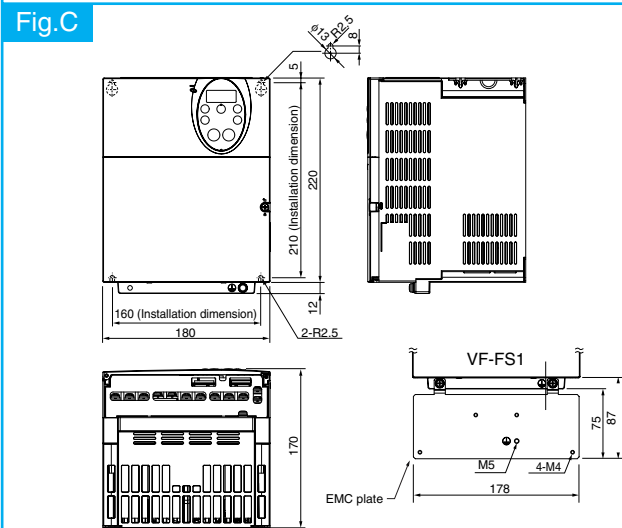
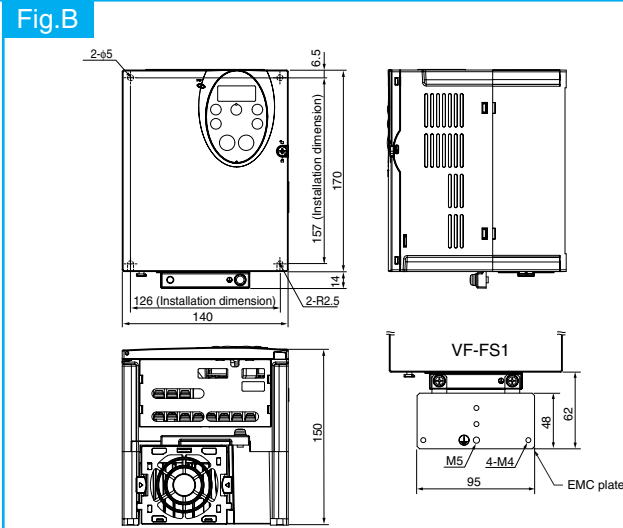
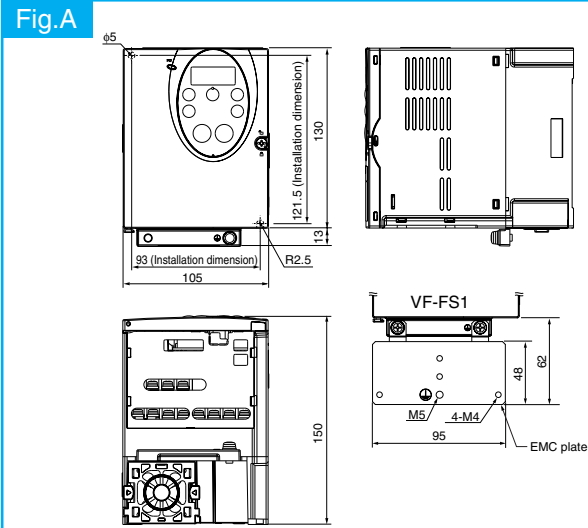

Note 1: To make it easier to grasp the dimensions of each inverter, dimensions common to all inverters in these figures are shown with numeric values but not with symbols.
Here are the meanings of the symbols used.
W: Width
H: Height
D: Depth
W1: Mounting dimension (horizontal)
H1: Mounting dimension (vertical)
H2: Height of EMC plate mounting area

Note 2: Here are the available EMC plate
Fig.A, Fig.B: EMP004Z (Approx. weight: 0.1kg)
Fig.C: EMP005Z (Approx. weight: 0.3kg)
Fig.D: EMP006Z (Approx. weight: 0.3kg)

Note 3: The models shown in Fig. A is fixed at two points: in the upper left and lower right corners.

Voltage class	Applicable motor (kW)	Inverter type	Dimensions (mm)						Drawing	Approx. weight (kg)
			W	H	D	W1	H1	H2		
3-phase 200V	0.4	VFFS1-2004PM	105	130	150	93	121.5	13	A	1.2
	0.75	VFFS1-2007PM								
	1.5	VFFS1-2015PM								
	2.2	VFFS1-2022PM								
	3.7	VFFS1-2037PM	140	170	150	126	157	14	B	2.1
	5.5	VFFS1-2055PM	180	220	170	160	210	12	C	4.3
	7.5	VFFS1-2075PM								
	11	VFFS1-2110PM	245	310	190	225	295	19.5	D	8.6
	15	VFFS1-2150PM								8.9
	18.5	VFFS1-2185PM								16.4
22	VFFS1-2220PM	240	420	214	206	403	—	E	16.4	
30	VFFS1-2300PM	320	630	290	280	605	—	F	38.0	
3-phase 400V	0.4	VFFS1-4004PL	105	130	150	93	121.5	13	A	1.4
	0.75	VFFS1-4007PL								
	1.5	VFFS1-4015PL								
	2.2	VFFS1-4022PL								
	3.7	VFFS1-4037PL	140	170	150	126	157	14	B	2.4
	5.5	VFFS1-4055PL	180	220	170	160	210	12	C	4.7
	7.5	VFFS1-4075PL								
	11	VFFS1-4110PL	245	310	190	225	295	19.5	D	9.0
	15	VFFS1-4150PL								15.4
	18.5	VFFS1-4185PL								
	22	VFFS1-4220PL	240	420	214	206	403	—	E	15.4
	30	VFFS1-4300PL								

Standard connection diagram

This diagram shows a standard wiring of the main circuit.

■Standard connection diagram-SINK (Negative) (common:CC)

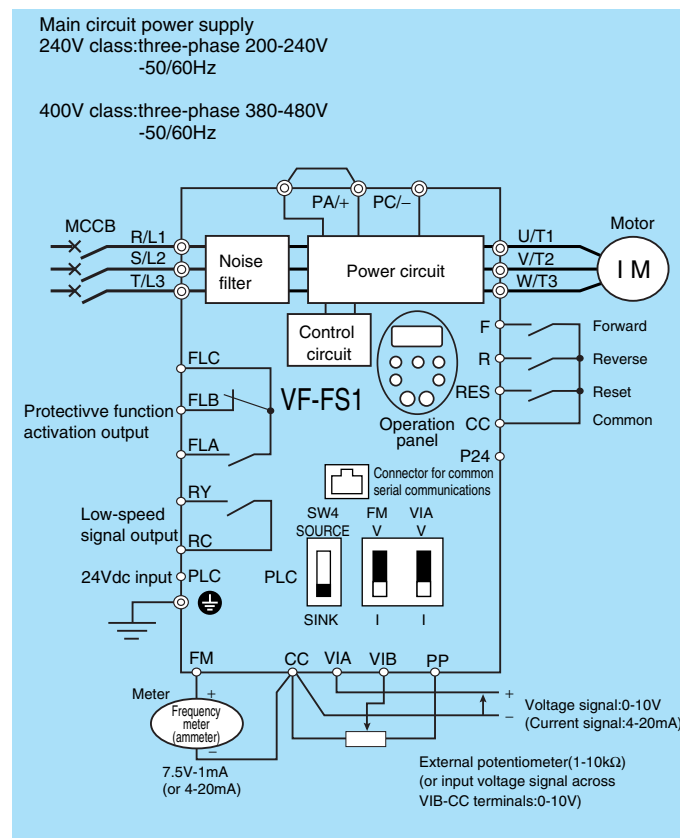

■Standard connection diagram - SOURCE (Positive) (common:P24)

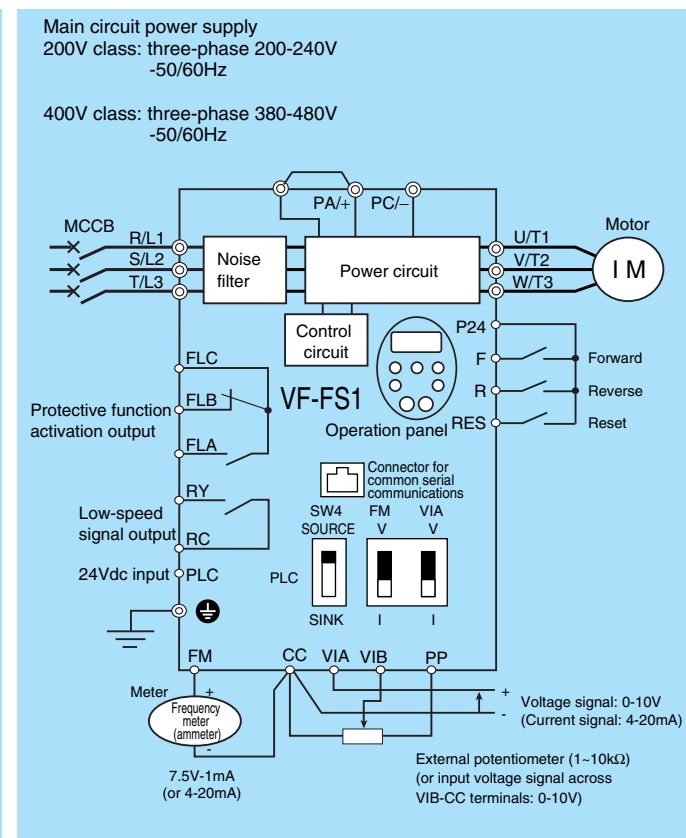

Main circuit terminal

Terminal symbol	Terminal function
	Grounding terminal for connecting inverter. There are 3 terminals in total. 2 terminals in the terminal board, 1 terminal in the cooling fin.
R/L1, S/L2, T/L3	200V class: three-phase 200 to 240V-50/60Hz 400V class: three-phase 380 to 480V-50/60Hz
U/T1, V/T2, W/T3	Connect to a (three-phase induction) motor.
PA+, PC/-	PA/+ terminal: Positive potential terminal for the internal DC main circuit PC/- terminal: Negative potential terminal for the internal DC main circuit DC power can be supplied through the PA/+ and PC/- terminals.

Control circuit terminal

Terminal symbol	Input/output	Function	Electrical specifications
F	Input	Multifunction programmable contact input	No voltage contact input 24Vdc-5mA or less *Sink/Source/PLC selectable using SW4
R	Input		
RES	Input	This inverter protective function is disabled if RES are CC is connected. Shorting RES and CC has no effect when the inverter is in a normal condition.	
PLC	Input (common)	External 24Vdc power input When the source logic is used, a common terminal is connected.	24VDC (Insulation resistance: DC50V)
CC	Common to Input/output	Control circuit's equipotential terminal (2 terminals)	—
PP	Output	Analog power supply output	10Vdc (permissible load current: 10mA)
VIA	Input	Multifunction programmable analog input. Factory default setting: 0~10Vdc/0~60Hz (0~50Hz) frequency input. The function can be changed to 4~20mAdc (0~20mA) current input by flipping the VIA (SW3) dip switch to the I position. By changing parameter setting, this terminal can also be used as a multifunction programmable contact input terminal. When using the sink logic, be sure to insert a resistor between P24-VIA (4.7 kΩ-1/2 W). Also move the VIA (SW3) dip switch to the V position.	10Vdc (internal impedance: 30kΩ) 4-20mA (internal impedance: 250Ω)
VIB	Input	Multifunction programmable analog input. Standard default setting: 0~10Vdc/0~60Hz (0~50Hz) frequency input. PTC thermal input	10Vdc (internal impedance: 30kΩ)
FM	Output	Multifunction programmable analog output. Standard default setting: output frequency. The function can be changed to 0-20mAdc (4-20mA) current output by flipping the FM (SW2) slide switch to the I position.	1mA full-scale ammeter or 7.5Vdc (10Vdc)1mA full-scale voltmeter 0-20mA (4-20mA) DC ammeter Permissible load resistance: 750Ω or less
P24	Output	24Vdc power output	24Vdc-50mA
FLA FLB FLC	Output	Multifunction programmable relay contact output. Detects the operation of the inverter's protection function. Contact across FLA-FLC is closed and FLB-FLC is opened during protection function operation.	250Vac-1A(cosφ=1): at resistance load 30Vdc-0.5A, 250Vac-0.5A(cosφ=0.4)
RY RC	Output	Multifunction programmable relay contact output. Standard default settings detect and output low-speed signal output frequencies. Multifunction output terminals to which two different functions can be assigned.	250Vac-1A(cosφ=1): at resistance load 30Vdc-0.5A, 250Vac-0.5A(cosφ=0.4)

Wiring devices

Voltage class	Capacity of applicable motor (kW)	Input current (A)		Wire size (See Note 4) For IEC60364-5-523/54		Molded case circuit breaker (MCCB) Earth leakage circuit breaker (ELCB)	Magnetic contactor (MC)
		200V class:200V 400V class:380V	200V class:240V 400V class:480V	Power circuit (mm ²) Note 1)	Earth cable (mm ²)		
Three-phase 200V class	0.4	1.9	1.6	1.5	2.5	3	25
	0.75	3.3	2.7	1.5	2.5	5	25
	1.5	6.1	5.1	1.5	2.5	10	25
	2.2	8.7	7.3	1.5	2.5	15	25
	3.7	15.7	13.0	2.5	2.5	30	25
	5.5	20.8	17.3	4	4	40	32
	7.5	27.9	23.3	6	6	50	40
	11	42.1	34.4	10	10	75	50
	15	56.1	45.5	16	16	100	80
	18.5	67.3	55.8	25	16	100	80
Three-phase 400V class Note 9)	0.4	1.0	0.8	1.5	2.5	3	25
	0.75	1.7	1.4	1.5	2.5	3	25
	1.5	3.2	2.5	1.5	2.5	5	25
	2.2	4.6	3.6	1.5	2.5	10	25
	3.7	8.1	6.4	1.5	2.5	15	25
	5.5	10.9	8.6	1.5	2.5	20	25
	7.5	14.7	11.7	1.5	2.5	30	32
	11	21.1	16.8	4	4	40	32
	15	28.5	22.8	6	6	50	40
	18.5	34.8	27.8	6	6	60	50
22	41.6	33.1	10	10	75	80	
30	56.7	44.7	16	16	100	80	

Note 1: Sizes of the wires connected to the input terminals R/L1, S/L2 and T/L3 and the output terminals U/T1, V/T2 and W/T3 when the length of each wire does not exceed 30m.

Note 2: For the control circuit, use shielded wires 0.75 mm² or more in diameter.

Note 3: For grounding, use a cable with a size equal to or larger than the above.

Note 4: The wire sizes specified in the above table apply to HV wires (copper wires shielded with an insulator with a maximum allowable temperature of 75°C) used at an ambient temperature of 40°C or less.

Note 5: If there is a need to comply with UL standard, use correct size of UL wires.

Note 6: Selections for use of the Toshiba 4-pole standard motor with power supply voltage of 200V/400V-50Hz.

Note 7: Choose the MCCB according to the power supply capacity.

For comply with UL and CSA standard, use the fuse certified by UL and CSA.

Note 8: When using on the motor side during commercial-power supply operation, choose the MC with class AC-3 rated current for the motor rated current.

Note 9: Attach surge killers to the magnetic contactor and exciting coil of the relay.

Note 10: In the case the magnetic contactor (MC) with 2a-type auxiliary contacts is used for the control circuit, raise the reliability of the contact by using 2a-type contacts in parallel connection.

Basic functions

Each “setup item” that determines the control characteristics of the inverter is called a “parameter.” For example, to change the acceleration time, you choose the acceleration time parameter (titled “ACC”).

wizard function

A wizard function enable set the 10 most often used parameter quickly. It can be sequentially, such as installing the PC software.

Title	Function
AWI	Automatic acceleration/deceleration
ACC	Acceleration time 1
DEC	Deceleration time 1
LL	Lower limit frequency
UL	Upper limit frequency
THR	Motor thermal protection
FN	Meter adjustment
PE	V/F control mode selection
UL	Base frequency 1
ULV	Base frequency voltage 1

Basic parameters

Title	Function	Adjustment range	Default setting
FC	Operation frequency of operation panel	LL - UL	0.0
AWF	Wizard function	The wizard function refers to the special function of calling up ten frequently used parameters.	—
AUH	History function	Displays parameters in groups of five in the reverse order to that in which their settings were changed. * (Possible to edit)	—
AW1	Automatic acceleration/deceleration	0: Disabled (manual) 1: Automatic 2: Automatic (only at acceleration)	0
AW4	Parameter setting macro function	0: Disabled 1: Coast stop 2: 3-wire operation 3: External input UP/DOWN setting 4: 4-20 mA current input operation	0
CNOd	Command mode selection	0: Terminal board 1: Operation panel 2: Serial communication	0
FNOd	Frequency setting mode selection 1	1: VIA 2: VIB 3: Operation panel 4: Serial communication 5: UP/DOWN from external contact	1
FNSL	Meter selection	0-19 (0:Output frequency 1:Output current 2:Set frequency 3.DC voltage 4: Output voltage command value, etc.)	0
FN	Meter adjustment	—	—
ESP	Default setting	0: - 1: 50Hz default setting 2: 60Hz default setting 3: Default setting (Initialization) 4: Trip record clear 5: Cumulative operation time clear 6: Initialization of type information 7: Save user setting parameters 8. Call user-defined parameters 9. Cumulative fan operation time record clear	0
FR	Forward/reverse run selection	0: Forward run 1: Reverse run 2: Forward run (F/R switching possible) 3: Reverse run (F/R switching possible)	0
ACC	Acceleration time 1	0.0-3200	Depends on capacity
DEC	Deceleration time 1	0.0-3200	Depends on capacity
FH	Maximum frequency	30.0-200.0	80.0
UL	Upper limit frequency	0.5-FH	50.0 (WP)/60.0 (WN)
LL	Lower limit frequency	0.0-UL	0.0
UL	Base frequency 1	25.0-200.0	50.0 (WP)/60.0 (WN)
ULV	Base frequency voltage 1	50-330 (200V class), 50-660 (400V class)	Depends on capacity
PE	V/F control mode selection	0: V/F constant 1: Variable torque 2: Automatic torque boost control 3: Vector control 4: Energy-saving 5: - (Do not select) 6: PM motor control	1
UB	Torque boost 1	0.0-30.0	Depends on capacity
THR	Motor electronic-thermal protection level 1	10-100	100
OLN	Electronic-thermal protection characteristic selection	0-3: Standard motor (Overload protection, OL stall) 4 -7: VF motor (Overload protection, OL stall)	0
SP1	Preset-speed operation frequency 1	LL - UL	15.0
SP2	Preset-speed operation frequency 2	LL - UL	20.0
SP3	Preset-speed operation frequency 3	LL - UL	25.0
SP4	Preset-speed operation frequency 4	LL - UL	30.0
SP5	Preset-speed operation frequency 5	LL - UL	35.0
SP6	Preset-speed operation frequency 6	LL - UL	40.0
SP7	Preset-speed operation frequency 7	LL - UL	45.0
F---	Extended parameters	Set parameters in more detail	—
GU	Automatic edit function	—	—

Extended parameters

About 170 extended parameters are available. For details on extended parameters, please visit our web site. (<http://www.inverter.co.jp/>)

Peripheral devices

No.	Device	Function and purpose
(1)	Input AC reactor (ACL)	Effective to reduce the harmonics (PWH) and suppress external surge on the inverter power source side. Install when a distorted wave generation source such as a thyristor unit or a large capacity inverter is connected in the same distribution system.
(2)	High-attenuation radio noise filter (NF type)	These types of filters are not necessary because all single-phase 240V or 3-phase 500V models have a built-in EMI noise filter, conforming to Class A, as standard. But install these filters if necessarily of noise reduction move and more. <ul style="list-style-type: none"> • Effective to prevent interference in audio equipment used near the inverter. • Install on the input side of the inverter. • Provided with wide-range attenuation characteristics from AM radio bands to near 10MHz. • Use when equipment readily affected by noise is installed in the peripheral area.
	Zero-phase reactor ferrite core-type	<ul style="list-style-type: none"> • Effective to prevent interference in audio equipment used near the inverter. • Effective in noise reduction on both input and output sides of the inverter. • Provided with attenuation characteristics of several dB in frequencies from AM radio bands to 10MHz. • For noise countermeasures, insert on the secondary side of the inverter.
(4)	EMC noise filter (Compliant with European standards)	A high-attenuation compact EMI noise filter that can be Foot-mounted and Side-mounted. With this filter on, the inverter complies with the following standards. <ul style="list-style-type: none"> • 400V class: EC/EN61800-3, 1st Environment, C1 or IEC/EN61800-3, 1st Environment, C2 • 200V class: EC/EN61800-3, 1st Environment, C2 or IEC/EN61800-3, 2nd Environment, C3
(5)	EMC plate	A steel plate used to connect shielded earth wires from inverter's power cables or to connect earth wires from external devices. Some models have it as a standard attachment or as an option.
(6)	Motor-end surge voltage suppression filter (for 400V class only)	Use an insulation-reinforced motor or install the surge voltage restraint filter to prevent degrading motor insulation caused by surge voltage generation depending on cable length and wiring method, or use of a 400V class motor driven with an inverter.
(7)	DIN rail kit	Available for the 2.2kW or less. (Model: DIN005Z)
(8)	LED extension panel (With parameter writer function)	This operation panel unit is for extension. It is provided with an LED display, RUN/STOP key, UP/DOWN key, monitor key, and enter key. Setup parameters for three inverters can be stored to this panel. (Type : RKP005Z)
(9)	USB communications conversion unit	This unit is connected to a PLC or a computer to enable data communications. By connecting the connector cable, parameters can be easily adjusted, and data easily saved and written. <ul style="list-style-type: none"> ■Monitor function ■Parameter setup function ■Command function ■Additional functions (Type : USB001Z)
(10)	Communications cable	Connector cable for LED extension
(11)	LonWorks® communications	This option enables LonWorks® communications with a host controller or other PLC. (Type :LIU007Z)
(12)	BACnet® communications option board	This option enables BACnet® communications with a host controller or other PLC. (Type :BCN002Z)
(13)	Metasys® N2 communications option board	This option enables Metasys® N2 communications with a host controller or other PLC. (Type :MTS002Z)
(14)	APOGEE® FLN communications option board	This option enables APOGEE® FLN communications with a host controller or other PLC. (Type :APG002Z)
(15)	Operation panel	Has a built-in frequency type, frequency setter and RUN-STOP (forward run, reverse run) switch. (model type: CBVR-7B1)

For inverter users

When studying how to use our inverters

Notes

Application of this inverter

VF-FS1 is not applicable for apparatus which needs sudden deceleration and stop. Also it can not be used for machine which requires continuous electrical braking (generators regeneration power) such as a winding machine.

Leakage current

This inverter uses high-speed switching devices for PWM control. When a relatively long cable is used for power supply to an inverter, current may leak from the cable or the motor to the ground because of its capacitance, adversely affecting peripheral equipment. The intensity of such a leakage current depends on the PWM carrier frequency, the lengths of the input and output cables, etc., of the inverter. To prevent current leakage, it is recommended to take the following measures.

[Effects of leakage current]

Leakage current, which increases when an inverter is used, may pass through the following routes:

- Route(1)...Leakage due to the capacitance between the ground and the noise filter
 - Route(2)...Leakage due to the capacitance between the ground and the inverter
 - Route(3)...Leakage due to the capacitance between ground and the cable connecting the inverter and the motor
 - Route(4)...Leakage due to the capacitance of the cable connecting the motor and an inverter in another power distribution line
 - Route(5)...Leakage through the grounding line common to motors
 - Route(6)...Leakage to another line because of the capacitance of the ground
- Leakage current, which passes through the above routes, may cause the following trouble.

- Malfunction of a leakage circuit breaker in the same or another power distribution line
- Malfunction of a ground-relay installed in the same or another power distribution line
- Noise produced at the output of an electronic device in another power distribution line
- Activation of an external thermal relay installed between the inverter and the motor, at a current below the rate current

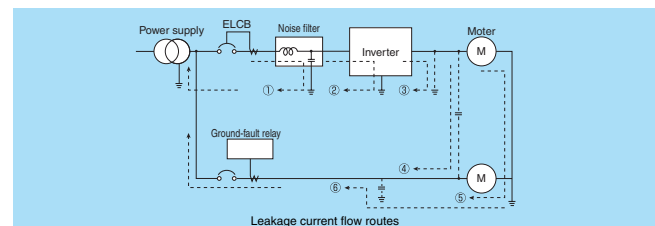

[Measures against effects of leakage current]

The measures against the effects of leakage current are as follows:

- 1) Measures to prevent the malfunction of leakage circuit breakers
 - (1)Decrease the PWM carrier frequency of the inverter. (Note)
 - (2)Use radio-frequency interference-proof ELCBs as ground-fault interrupters in not only the system into which the inverter is incorporated but also other systems. When ELCBs are used, the PWM carrier frequency needs to be increased to operate the inverter.
 - (3)When connecting multiple inverters to a single ELCB, use an ELCB with a high current sensitivity or reduce the number of inverters connected to the ELCB.
- 2) Measures against malfunction of ground-fault relay:
 - (1)Decrease the PWM carrier frequency of the inverter. (Note)
 - (2)Install ground-fault relays with a high-frequency protective function (e.g., Toshiba CCR12 type of relays) in both the same and other lines. When ELCBs are used, the PWM carrier frequency needs to be increased to operate the inverter.
- 3) Measures against noise produced by other electric and electronic systems:
 - (1)Separate the grounding line of the inverter from that of the affected electric and electronic systems.
 - (2)Decrease the PWM carrier frequency of the inverter. (Note)
- 4) Measures against malfunction of external thermal relays:
 - (1)Remove the external thermal relay and use the electronic thermal function of the inverter instead of it. (Inapplicable to cases where a single inverter is used to drive more than one motor. Refer to the instruction manual for measures to be taken when thermal relays cannot be removed.)
 - (2)Decrease the PWM carrier frequency of the inverter. (Note)

(Note) This inverter allows you to decrease the frequency up to 6.0kHz. If the carrier frequency reduce, the acoustic noise caused by the motor increase.

- 5) Measures by means of wiring and grounding
 - (1)Use a grounding wire as large as possible.
 - (2)Separate the inverter's grounding wire from that of other systems or install the grounding wire of each system separately to the grounding point.
 - (3)Ground (shield) the main circuit wires with metallic conduits.
 - (4)Use the shortest possible cables to connect the inverter to the motor.
 - (5)If the inverter has a high-attenuation EMI filter, turn off the grounding capacitor detachment switch to reduce the leakage current. Note that doing so leads to a reduction in the noise attenuating effect.

Ground fault

Before beginning operation, thoroughly check the wiring between the motor and the inverter for incorrect wiring or short circuits. Do not ground the neutral point of any star-connected motor.

Radio interference

[Noise produced by inverters]
Since this inverter performs PWM control, it produces noise and sometimes affects nearby instrumental devices, electrical and electronic systems, etc. The effects of noise greatly vary with the noise resistance of each individual device, its wiring condition, the distance between it and the inverter, etc.
[Measures against noises]

According to the route through which noise is transmitted, the noises produced by an inverter are classified into transmission noise, induction noise and radiation noise. [Examples of protective measures]

- Separate the power line from other lines, such as weak-current lines and signal lines, and install them apart from each other.
- Install a noise filter in each inverter. It is effective for noise prevention to install noise filters in other devices and systems, as well.
- Shield cables and wires with grounded metallic conduits, and cover electronic systems with grounded metallic cases.
- Separate the power distribution line of the inverter from that of other devices and systems.
- Install the input and output cables of the inverter apart from each other.
- Use shielded twisted pair wires for wiring of the weak-current and signal circuits, and always ground one of each pair of wires.
- Ground the inverter with grounding wires as large and short as possible, separately from other devices and systems. The three-phase 400V models have built-in noise filters, which significantly reduce noise.

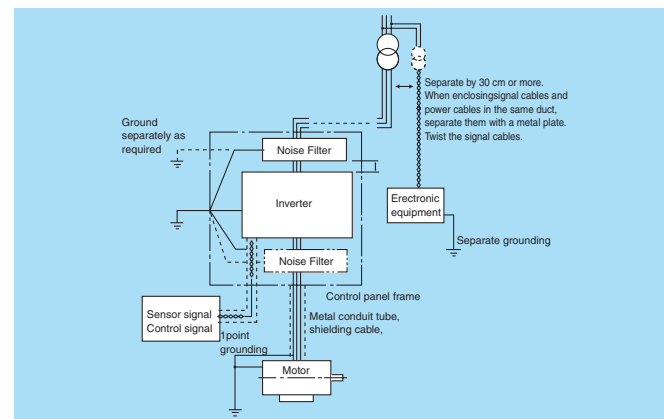

Power factor improvement capacitors

Do not install a power factor improvement capacitors on the input or output side of the inverter.

Installing a power factor improvement capacitor on the input or output side causes current containing harmonic components to flow into the capacitor, adversely affecting the capacitor itself or causing the inverter to trip. To improve the power factor, install an input AC reactor (optional) on the primary side of the inverter.

Installation of input AC reactors

These devices are used to improve the input power factor and suppress high harmonic currents and surges. Install an input AC reactor when using this inverter under the following conditions:

- (1) When the power source capacity is 200kVA or more, and when it is 10 times or more greater than the inverter capacity.
- (2) When the inverter is connected the same power distribution system as a thyristor-committed control equipment.
- (3) When the inverter is connected to the same power distribution system as that of distorted wave-producing systems, such as arc furnaces and large-capacity inverters.

When wiring the inverter

Wiring precautions

Installing a molded-case circuit breaker [MCCB]

- (1) Install a molded-case circuit breaker (MCCB) on the inverter's power supply input to protect the wiring.
- (2) Avoid turning the molded-case circuit breaker on and off frequently to turn on/off the motor.
- (3) To turn on/off the motor frequently, close/break the control terminals F (or R)- CC.

Installing a magnetic contactor [MC] [primary side]

- (1) To prevent an automatic restart after the power interruption or overload relay has tripped, or actuation of the protective circuit, install an electro-magnetic contact in the power supply.
- (2) The inverter is provided with a failure detection relay (FL), so that, if its contacts are connected to the operation circuit of the magnetic contactor on the primary side, the magnetic contactor will be opened when the protective circuit of the inverter is activated.
- (3) The inverter can be used without a magnetic contactor. In this case, use an MCCB (equipped with a voltage tripping device) for opening the primary circuit when the inverter protective circuit is activated.
- (4) Avoid turning the magnetic contactor on and off frequently to turn on/off the motor.
- (5) To turn on/off the motor frequently, close/break the control terminals F (or R)- CC.

Installing a magnetic contactor [MC] [secondary side]

- (1) As a rule, if a magnetic contactor is installed between the inverter and the motor, do not turn ON/OFF while running. (If the secondary-side contactor is turned ON/OFF while running, a large current may flow in the inverter, causing inverter damage and failure.)
- (2) A magnetic contactor may be installed to change the motor or change to the commercial power source when the inverter is stopped. Always use an interlock with the magnetic contactor in this situation so that the commercial power supply is not applied to the inverter's output terminals.

External signal

- (1) Use a relay rated for low currents. Mount a surge suppressor on the excitation coil of the relay.
- (2) When wiring the control circuit, use shielded wires or twisted pair cables.
- (3) All control terminals, except FLA, FLB and FLC are electronic circuits. Therefore, input signal must insulate with power circuit.

Installing an overload relay

- (1) The VF-FS1 inverter has an electronic-thermal overload protective function. However, in the following cases, the thermal relay operation level must be adjusted or an overload relay matching the motor's characteristics must be installed between the inverter and the motor.
 - (a) When using a motor having a rated current value different from that of the equivalent.
 - (b) When driving several motors simultaneously.
- (2) When using the inverter to control the operation of a constant-torque motor (VF motor), change the protective characteristic of the electronic thermal relay according to the setting of the VF motor.
- (3) In order to adequately protect a motor used for low-speed operation, we recommend the use of a motor equipped with an embedded thermal relay.

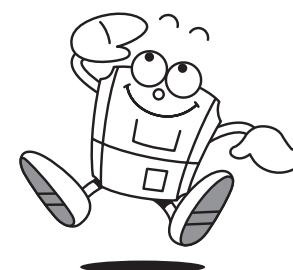

When changing the motor speed

Application to standard motors

Vibration

When a motor is operated with an industrial inverter, it experiences more vibrations than when it is operated by the commercial power supply. The vibration can be reduced to a negligible level by securing the motor and machine to the base firmly. If the base is weak, however, the vibration may increase at a light load due to resonance with the mechanical system.

Reduction gear, belt, chain

Note that the lubrication capability of a reducer or a converter used as the interface of the motor and the load machine may be affected at low speeds. When operating at a frequencies exceeding 60 Hz or higher, power transmission mechanisms such as reduction gear, belts and chains, may cause problems such as production of noise, a reduction in strength, or shortening of service life.

Frequency

Before setting the maximum frequency to 60 Hz or higher, confirm that this operating range is acceptable for the motor.

Application to special motors

Gear motor

When using an industrial inverter to drive a gear motor, inquire of the motor manufacturer about its continuous operation range, since low-speed operation of a gear motor may cause insufficient lubrication.

Toshiba Gold Motor (High-efficiency power-saving motor)

Inverter-driven operation of Toshiba Gold Motors is the best solution for saving energy. This is because these motors have improved efficiency, power factor, and noise/vibration reduction characteristics when compared to standard motors.

Pole-changing motor

Pole-changing motors can be driven by this inverter. Before changing poles, however, be sure to let the motor come to a complete stop.

Multipolar motors

Note that multipolar motors(8 or more poles), which may be used for fans, etc., have higher rated current than 4-pole motors. The current ratings of multipolar motors are relatively high. So, when selecting an inverter, you must pay special attention to its current rating so that the current rating of the motor is below that of the inverter.

Single-phase motor

Because single-phase motors are equipped with a centrifugal switch and capacitors for starting, they cannot be driven by an inverter. If only a single-phase, power system is available a 3-phase motor can be driven by using a single-phase input inverter to convert it into a 3-phase 240V output. (A special inverter and a 3-phase motor are required.)

Braking motor

When using a braking motor, if the braking circuit is directly connected to the inverters's output terminals, the brake cannot be released because of the lowered starting voltage. Therefore, when using a braking motor, connect the braking circuit to the inverter's power supply side, as shown on the left. Usually, braking motors produce larger noise in low speed ranges.

Note: In the case of the circuit shown on the left, assign the function of detecting low speed signals to the RY and RC terminals. Make sure the parameter F130 is set to 4 (factory default setting).

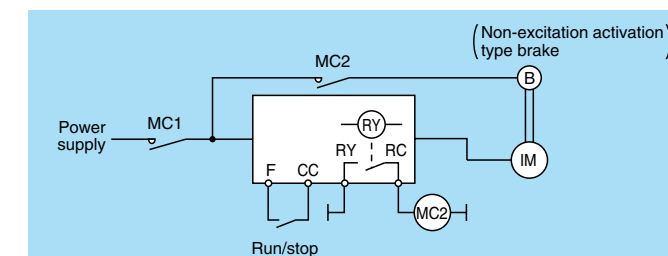

Selecting the capacity (model) of the inverter

Selection

Capacity

Refer to the applicable motor capacities listed in the standard specifications. When driving a high-pole motor, special motor, or multiple motors in parallel, select such an inverter that the sum of the motor rated current multiplied by 1.05 to 1.1 is less than the inverter's rated output current value.

Acceleration/deceleration times

The actual acceleration and deceleration times of a motor driven by an inverter are determined by the torque and moment of inertia² of the load, and can be calculated by the following equations.

The acceleration and deceleration times of an inverter can be set individually. In any case, however, they should be set longer than their respective values determined by the following equations.

Acceleration time	$t_a = \frac{(J_M + J_L) \times \Delta N}{9.56 \times (T_M - T_L)} \text{ (sec)}$
Deceleration time	$t_a = \frac{(J_M + J_L) \times \Delta N}{9.56 \times (T_B + T_L)} \text{ (sec)}$
Conditions	<p>J_M: Moment of inertia of motor (kge.m²) J_L: Moment of inertia of load (kge.m²) (converted into value on motor shaft) ΔN: Difference in rotating speed between before and after acc. or dec. (min.⁻¹) T_L: Load torque (Ne.m) T_M: Motor rated torque x 1.1 (Ne.m) ... V/f control : Motor rated torque x 1.2 (Ne.m) ... Vector operation control T_B: Motor rated torque x 0.05 (Ne.m)</p>

Allowable torque characteristics

When a standard motor is combined with an inverter to perform variable speed operation, the motor temperature rises slightly higher than it normally does during commercial power supply operation. This is because the inverter output voltage has a sinusoidal (approximate) PWM waveform. In addition, the cooling becomes less effective at low speed, so the torque must be reduced according to the frequency. When constant-torque operation must be performed at low speeds, use a Toshiba VF motor designed specifically for use with inverters.

[An example of V/F control at a base frequency of 60 Hz]

Note 1. 100% of torque refers to the amount of torque that the motor produces when it is running at a 60Hz-synchronized speed. The starting torque is smaller in this case than that required when power is supplied from a commercial power line. So, the characteristics of the machine to be operated need to be taken into consideration.

Note 2. The maximum allowable torque at 50Hz can be calculated approximately by multiplying the maximum allowable torque at a base frequency of 60Hz by 0.8.

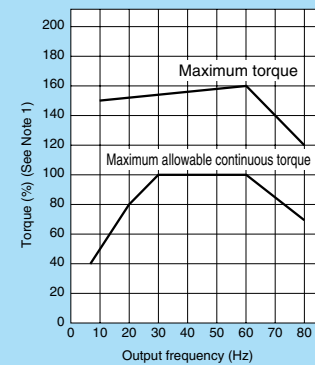

Starting characteristics

When a motor is driven by an inverter, its operation is restricted by the inverter's overload current rating, so the starting characteristic is different from those obtained from commercial power supply operation.

Although the starting torque is smaller with an inverter than with the commercial power supply, a high starting torque can be produced at low speeds by adjusting the V/f pattern torque boost amount or by employing vector control.

When a larger starting torque is necessary, select an inverter with a larger capacity and examine the possibility of increasing the motor capacity.

If you need bigger starting torque, please consider both upgrading inverter rating and motor rating.

Harmonic current and influence to power supply

Harmonics are defined as sinusoidal waves that is multiple frequency of commercial power (base frequency: 50Hz or 60Hz). Commercial power including harmonics has a distorted waveform.

Some electrical and electronic devices produce distorted waves in their rectifying and smoothing circuits on the input side. Harmonics produced by a device influence other electrical equipment and facilities in some cases (for example, overheating of phase advancing capacitors and reactors).

For this inverter, Toshiba unique technologies suppress harmonics, particularly 5th and 7th harmonic current that affect power sources. And the power factor in all models has been improved. Harmonics are controlled to within the Total Harmonic Distortion (THD) of international standard IEC61000-3-12 without any external reactor. (Rsce \geq 120) Optional AC reactor enables to comply with Partial Weighted Harmonic Distortion (PWHd) of IEC 61000-3-12. (Rsce \geq 120)

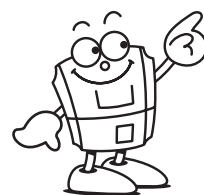

To users of our inverters : Our inverters are designed to control the speeds of three-phase induction motors for general industry.

 **Precautions**

- * Read the instruction manual before installing or operating the inverter unit and store it in a safe place for reference.
- * When using our inverters for equipment such as nuclear power control, aviation and space flight control, traffic, and safety, and there is a risk that any failure or malfunction of the inverter could directly endanger human life or cause injury, please contact our headquarters, branch, or office printed on the front and back covers of this catalogue. Special precautions must be taken and such applications must be studied carefully.
- * When using our inverters for critical equipment, even though the inverters are manufactured under strict quality control always fit your equipment with safety devices to prevent serious accident or loss should the inverter fail (such as issuing an inverter failure signal).
- * Do not use our inverters for any load other than three-phase induction motors.
- * None of Toshiba, its subsidiaries, affiliates or agents, shall be liable for any physical damages, including, without limitation, malfunction, anomaly, breakdown or any other problem that may occur to any apparatus in which the Toshiba inverter is incorporated or to any equipment that is used in combination with the Toshiba inverter. Nor shall Toshiba, its subsidiaries, affiliates or agents be liable for any compensatory damages resulting from such utilization, including compensation for special, indirect, incidental, consequential, punitive or exemplary damages, or for loss of profit, income or data, even if the user has been advised or apprised of the likelihood of the occurrence of such loss or damages.

**For further information, please contact your nearest Toshiba Representative or International Operations-Producer Goods.
The information in this brochure is subject to change without notice.**

TOSHIBA

TOSHIBA CORPORATION
INDUSTRIAL AND POWER SYSTEMS & SERVICES COMPANY

Overseas Sales & Marketing Department
Electrical Apparatus & Measurement Division
1-1, Shibaura 1-chome, Minato-ku,
Tokyo 105-8001, Japan
Tel.: +81(0)3-3457-4911 Fax.: +81(0)3-5444-9268

06-02 (AB)8698 